



**DICKOW
PUMPEN**



**Vertical selfpriming
Side-Channel Pumps**

Type WPV

Field of application

The side-channel pumps are selfpriming and operate more economically (better efficiency) than normal centrifugal pumps when handling low flows and high heads.

Due to these facts, the side-channel pumps are appropriate to solve many pumping problems in industrial processes. They can be used for almost all liquids which are free of any abrasive solids and of suitable viscosity. Application limit for selfpriming design is 115 cSt.

The vertical side-channel pumps are suitable especially for tank farms with underground storage tanks with a diameter of max 2,5 m (8.2 ft). The design of the pumps allows an installation directly on the dome cover. That means, suction lift is only slightly above the tank diameter and the suction pipe can be kept short.

The maximum allowable operating pressures are 6 bar (PN6) and 10 bar (PN16), the maximum operating temperatures are 100°C (212°F).

Design

The WPV-types are single stage, single flow, selfpriming Inline-pumps. The opposite located suction- and discharge flanges have identical nominal diameters. The pump consists of the socket, the suction and pressure disc, the bearing housing with mechanical seal and the impeller.

For the sizes 25/35/40 a design with oval flanges PN6 and impeller arrangement without SiC-rings is available.

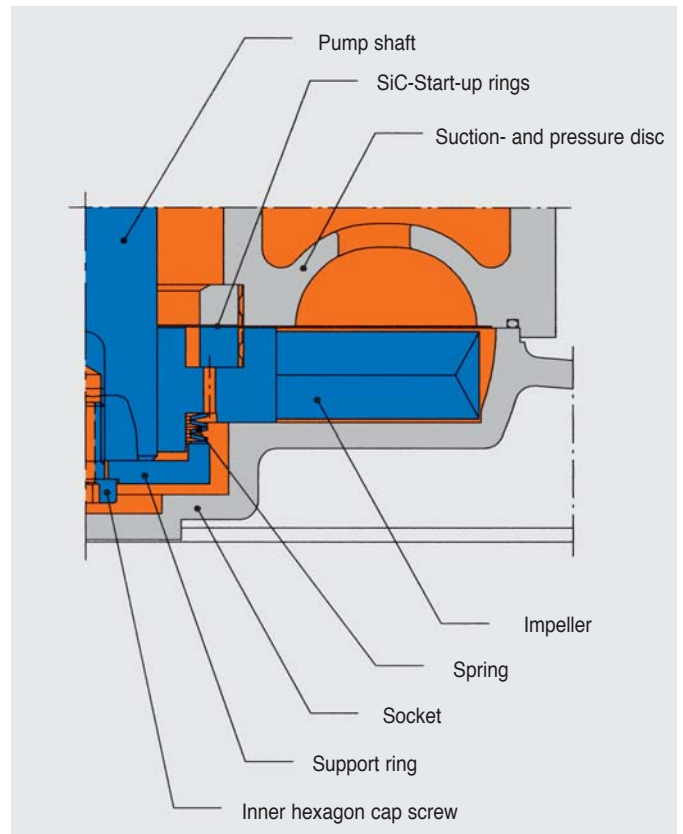

Impeller, design PN16

The hydraulically balanced side-channel impeller is keyed to the extended motor shaft and located in a chamber between the socket and the suction and pressure disc. To achieve selfpriming capability, best efficiency and differential pressure, tight clearances between the rotating impeller and the stationary pump parts are required.

To avoid seizing of the impeller due to the tight internal clearances, the pumps are fitted with additional wear resistant SiC-rings. The SiC-rings are placed in the suction and pressure disc as well as in the impeller hub. The impeller is pushed concentric to the ring in the disc by the spring and the support ring. With this design, a clearance is guaranteed between impeller vanes and the stationary parts. Metallic contact between the parts and seizing is excluded.

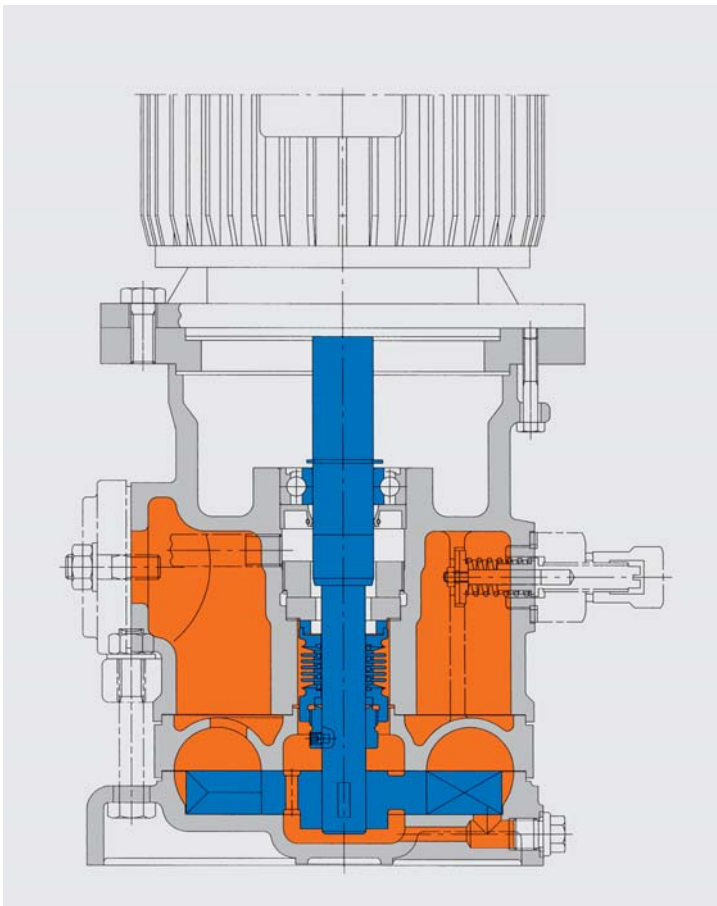

Sectional drawing, design PN16

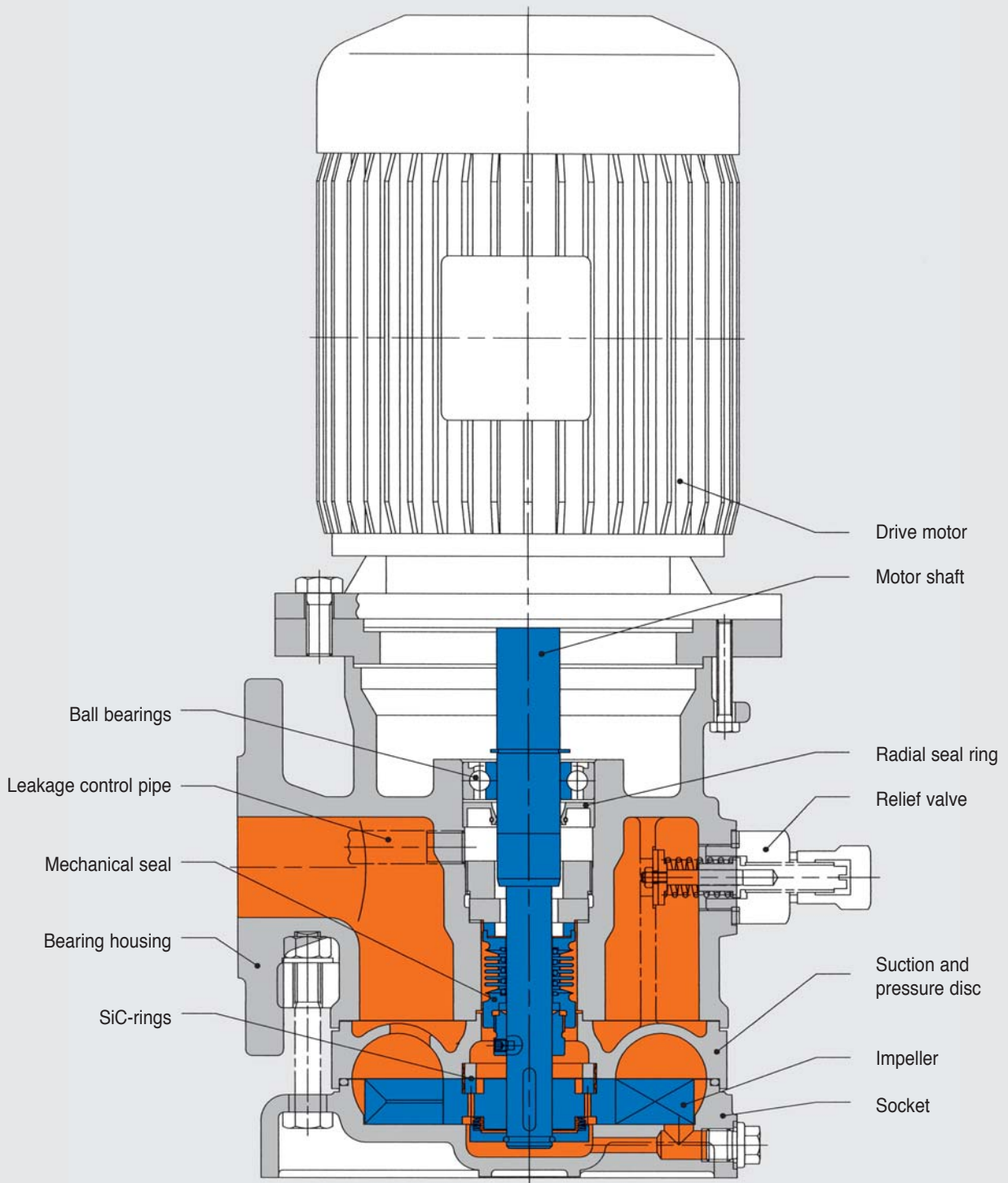

Mechanical seal

The pumped liquid is sealed against the atmosphere and the drive motor by a single metal bellows seal.



The rotating mechanical seal is fitted to the pump shaft by the shaft nut and the static seal ring. The stationary seal face is fitted to the bearing housing and sealed against the atmosphere by a gasket. The drive motor is protected against mechanical seal leakage by the grease lubricated radial seal ring. Seal leakage can be monitored by the leakage control pipe which is screwed to the bearing housing.

Standard material

Bearing housing	GG25 (PN6), GGG40.3, 1.4408 (PN16)
Socket, suction and pressure disc	GGG40.3, 1.4408
Impeller	Ms (PN6), 1.4457 (PN16)
Motor shaft	St, 1.4571
Mechanical seal	Metal bellows 1.4571, seal faces SiC/Carbon
Start-up rings	SiC
Relief valve	Ms, 1.4571

Drive motors

IEC-motors with extended shaft, design V1, will be applied.
Standard rotating speed 1450 rpm / 50 Hz, 1750 rpm / 60 Hz.

Hazardous area

Together with the required Ex-drive motors, the WPV-pumps can be applied in hazardous area Group II, Category 2. The pumps meet the basic safety and health requirements of Explosion-proof Directive 94/9 EC and Machinery Directive 98/37 EC and are suitable for plants with increased safety requirements.

Relief valve

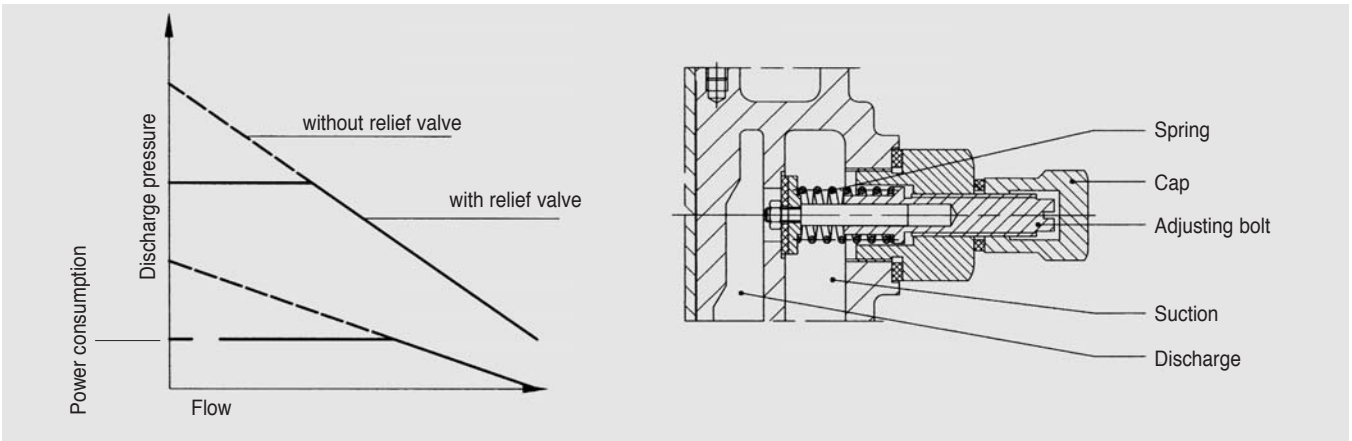

Contrary to centrifugal pumps, the side channel pumps generate a steep head rise and an increased power consumption at lower flow rates. Power consumption and discharge pressure reach the maximum at closed discharge. To protect discharge pipes and to avoid overload of the motors and unacceptable temperature rise in the pump, additional relief valves can be fitted to the WPV-pumps.

Installation at site, suction piping

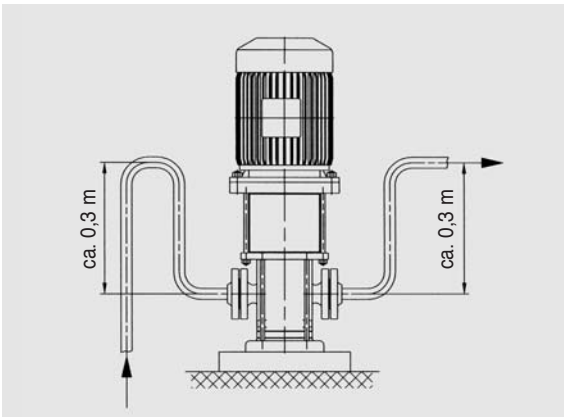

During the suction phase – when priming the empty suction line – the side-channel pumps build up a gas/liquid mixture. The gas or air will be separated and pressed into the pressure pipe while the operating liquid returns to the pump. It is therefore necessary to install the piping in a way that the operating liquid can remain in the pump.

Side-channel pumps with their tight internal clearances do not tolerate solids or abrasives in the pumped liquid. Solids, such as welding beads or forging scales, concentrate on the bottom of the suction vessel. This should be considered when connecting suction line to suction vessel.

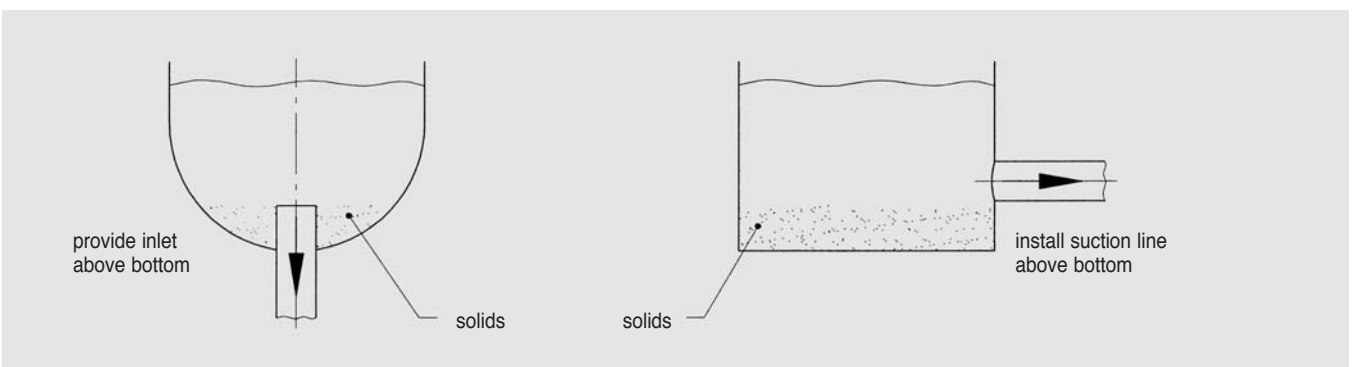

Performance range

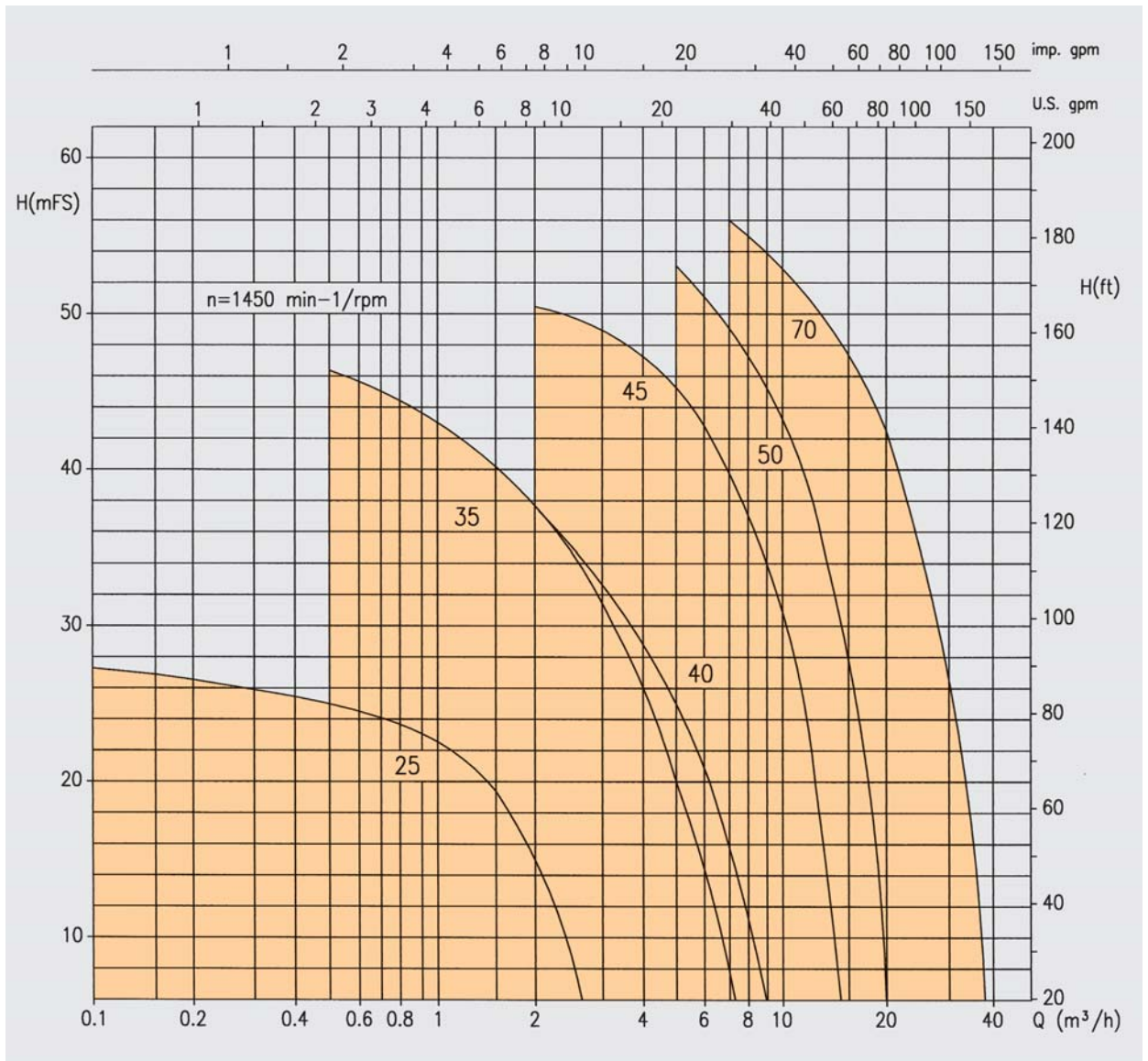

Performance curves of the individual pump sizes, also for 1750 rpm, with NPSH-values and power consumption are available on request.