

# ROTOMAC™

## PROGRESSIVE CAVITY PUMPS

'FAS' HYGIENIC SERIES

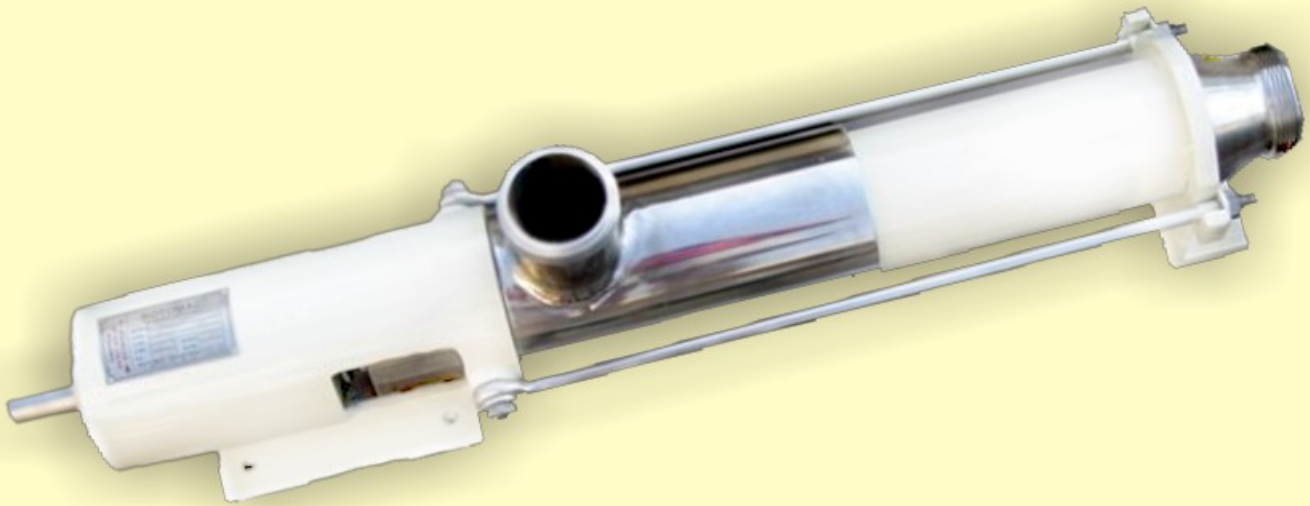

FLOW RATE : Upto 100 M<sup>3</sup> / Hr  
DIFFERENTIAL PRESSURE : Upto 24 bar (for more system pressures, contact factory assistance)  
VISCOSITY : Upto 100,000 cSt  
TEMPERATURE : Upto 150°C



Compliant

## PRINCIPLE

The main components which characterise the pump are a metallic single helical rotary part ROTOR and fixed double helical resilient polymer part STATOR in which the rotor turns and thereby a complex progressive sealing line ( cspl) is maintained. Whilst the rotor rotates inside the stator, the cavities formed between them progresses from suction to discharge end, gently carrying the media.

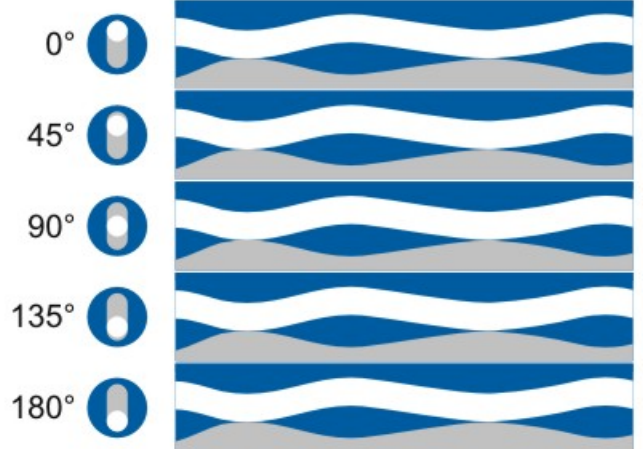

**Cavity Movement at Different Rotor Settings**

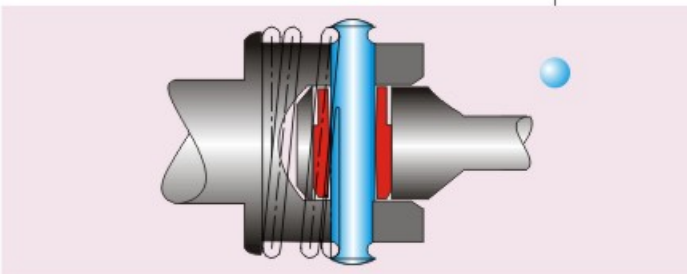
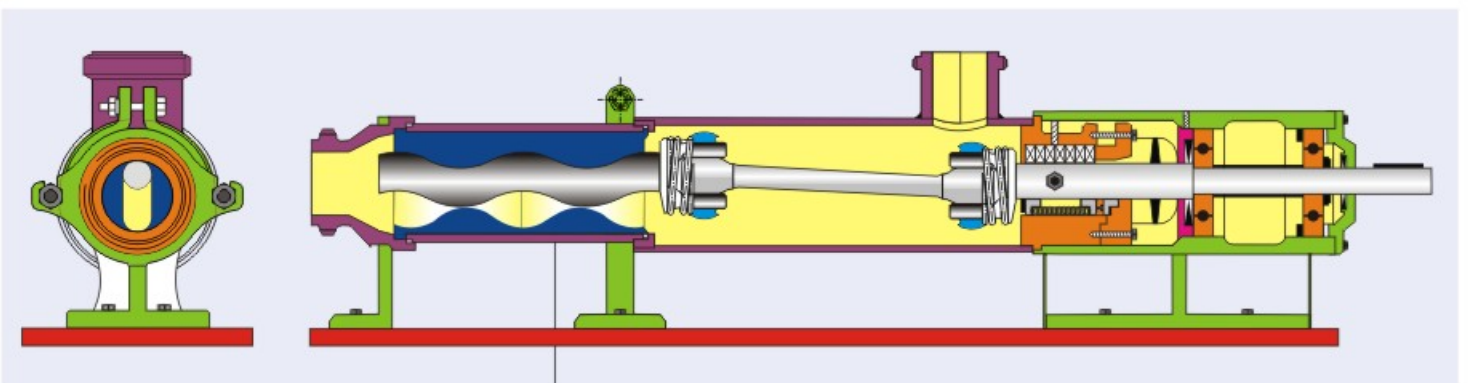

## UNIVERSAL JOINT

User friendly, completely sealed pin & bush joints for a longer service life.

## DRIVE ARRANGEMENTS

### DIRECT DRIVE

Electric Motor, Geared Motor, Gear Box, Mechanical Speed Variator, Eddy Current DC Drive, Hydraulic, Pneumatic, Petrol & Diesel Engines.

For accurate and variable flow rates, AC Variable Frequency Drives can be used.

### PULLEY & V-BELT DRIVE

Overhead & 'L' Type

## SHAFT SEALING

A wide variety of gland packed & mechanical seal options with API plan.

## MATERIAL OPTIONS

**HOUSING PARTS** AISI304, AISI316, AISI316L.

**ROTOR & SHAFT** AISI304, AISI316, AISI316L.

**STATOR** NBR, HNBR, EPDM, CSM, Q,  
White, food grade, abrasion  
resistant & high temperature  
resistant variants.



## INDUSTRIES

Breweries, Canning, Chocolate, Coffee & Tea, Confectionery, Cosmetics, Dairy, Food & Fruit Processing, Gelatin, Glucose, Ice Cream, Laboratories, Medicines, Pharmaceuticals, Starch, Sweets, Winery Etc.

## FLUIDS HANDLED

Amla Pulp, Beer, Beverages, Butter, Butter Oil, Casein, Chocolates, Creams, Curd, Demineralised Water, Diced Vegetables, Edible Gelatin, Edible Oils, Fruit Pulp, Cubes, & Juices, Glucose, Ghee, Honey, Ice Creams Mix, Instant Coffee & Tea, Jams, Liquid Glucose, Latex, Liquors, Lotions & Creams, Malt Extracts, Medicinal Formulations & syrups, Milk, Shampoo, Starch, Sugar Syrup, Squashes, Tamarind Extract, Tomato Ketchup/paste, Tooth Pastes, Vegetable Refined Oil, vegetable Extracts, Wines, Yeast Etc.

## ADVANTAGES

<b>POSITIVE DISPLACEMENT</b>	Progressing cavities deliver a uniform, metered and non-pulsating flow. The head developed is independent, and flow rate proportionate to the rotational speed.
<b>SELF PRIMING</b>	Can work on snore i.e., handles high percentage of air with liquid and do not require foot valves.
<b>NON CLOGGING</b>	Can handle solids in suspension or media containing high percentage of solids.
<b>LOW INTERNAL VELOCITY</b>	Minimum degradation of shear-sensitive media and can handle highly viscous pseudo-plastic materials.
<b>LOW NPSH REQUIREMENT</b>	Suction lift capability up to 9.5 MWC and effective even in high vacuum conditions.
<b>REVERSIBLE</b>	Suction and Delivery ends can be interchanged by merely changing the direction of rotation of the pump.
<b>SILENT RUNNING</b>	The rotor rotates inside a resilient stator, thus generation minimal noise.

## INTEGRAL SAFETY RELIEF VALVE

Recommended for plant safety wherever the possibility of the pump running against a closed valve or in-line blockade exists.

## DRY RUNNING PROTECTION

The temperature between the rotor and the stator is permanently sensed thermoelectrically via a temperature sensor integrated in the stator and compared with the limit value set at the TSE control unit.

When the pump runs dry, the temperature will rise due to the increased friction between the rotor and the stator. When the set limit value has been reached, the TSE control unit switches off the pump drive and triggers a fault message to trip the moto.

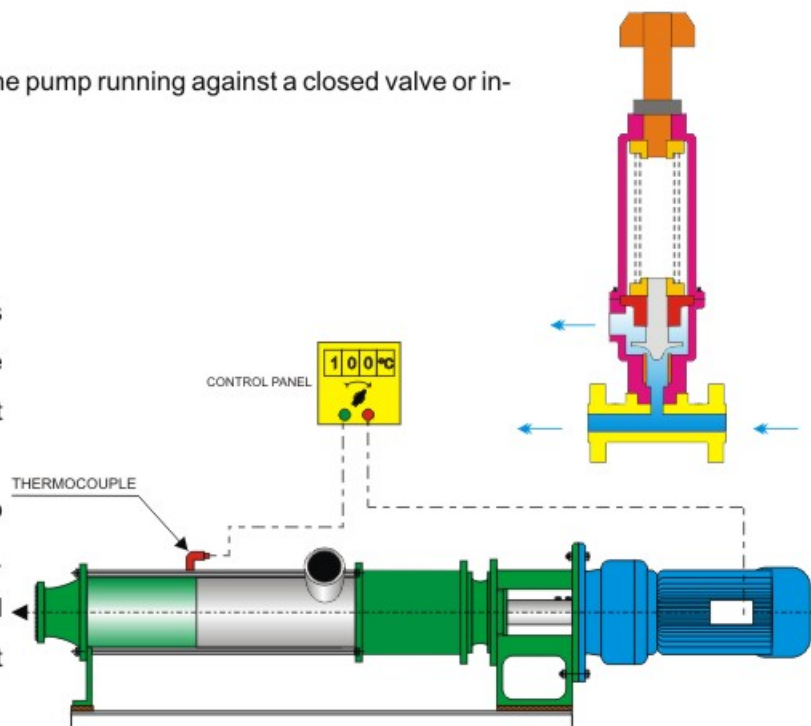

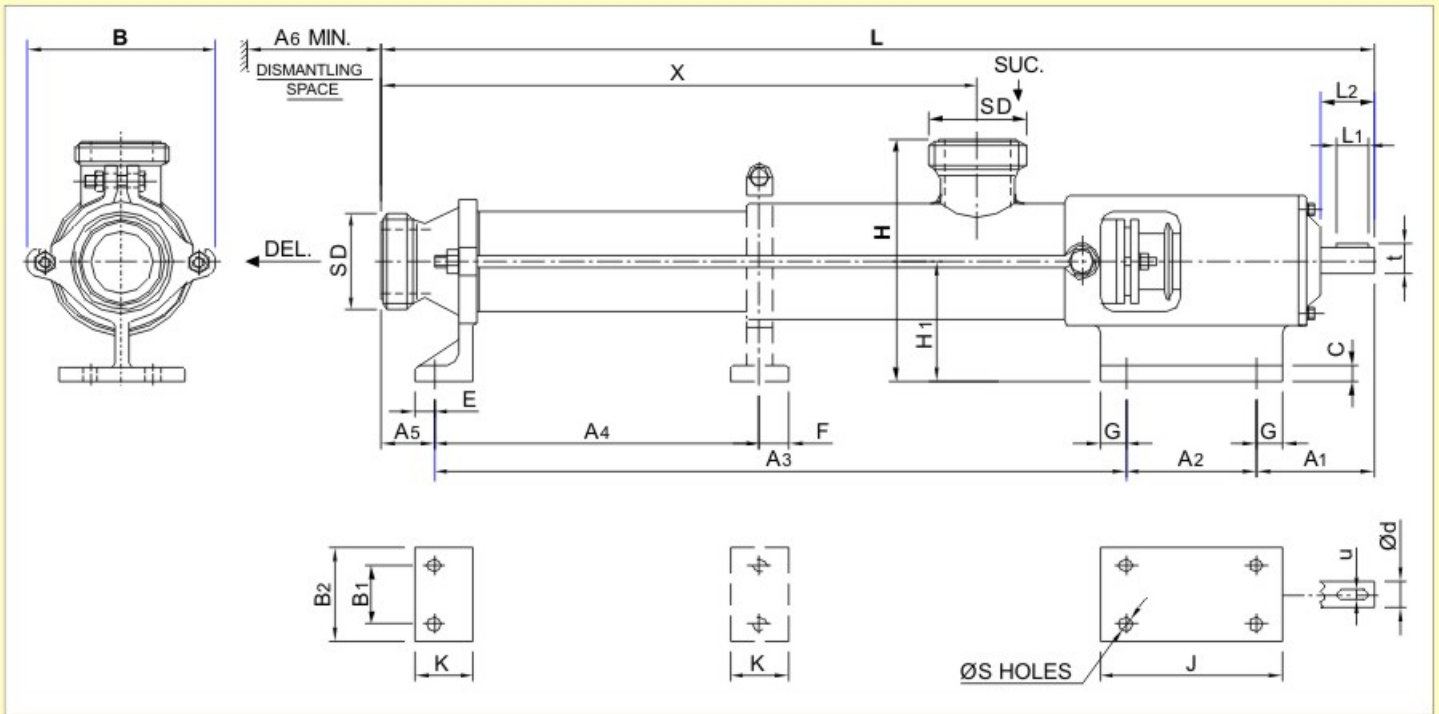

PUMP TYPE	PUMP SIZE	BASIC DIMENSIONS																			SUC. / DEL.			SHAFT EXTN.				W	
		L	B	H	A1	A2	A3	A4	A5	A6	B1	B2	C	E	F	G	J	H1	K	S	X	SMS/DIN/IDF	d	t	u	L1	L2		
FAS	01561	492					285													220									9.0
FAS	01562	570					363													298									10.0
FAS	01564	726	118	155	86	107	519		14	350	50	78	8	15		19	145	90	45	10	454	1 1/2"	14	16	5	20	28	12.0	
FAS	02081	520					313													248								11.0	
FAS	02082	624					417													352								13.0	
FAS	02084	1005					688													648								30.0	
FAS	03121	749					432													392								25.0	
FAS	03122	905	152	200	106	177	588		34	550	70	110	10			15	207	100	54	10	548	2"	22	25	6	40	51	28.0	
FAS	03501	961					644	422												604								16	
FAS	03801	866					549	*												509								16	
FAS	03802	1106					789	567												709								16	
FAS	04301	1209					878	580						20						811								53.0	
FAS	03124	1314	175				983	685	46											916								56.0	
FAS	04161	903		234	135	150	572	*		750	78	118	12						505									40.0	
FAS	04162	1111					780	482								20	190	112	58	12	713	2 1/2"	28	31	8	40	52	48.0	
FAS	05001	1052	186				723	420	44											654								50.0	
FAS	04164	1758					1358	901												1279								85.0	
FAS	05201	1278	215	277	173	178	878	421	49	750	94	134	14	25	30	36	250	132	70	15	799	3"	32	35	10	60	78	94.0	
FAS	05202	1628					1228	771												1149								107.0	
FAS	05204	2433					1961	1476												1890								165.0	
FAS	06241	1353					881	396												810								154.0	
FAS	06242	1665	260	325	168	200	1193	708	54	1450	110	152	15	25	30	30	260	160	75	18	1122	4"	38	40	10	60	83	174.0	
FAS	07281	1428					956	471												885								178.0	

### NOTES:-

1. ALL DIMENSIONS ARE IN m.m. AND FOR GUIDANCE ONLY, EXCEPT WHERE OTHERWISE STATED.
2. SHAFT DIAMETERS ARE TO BS 4506:1970 AND KEYWAYS TO BS 4235:1982 PART I AND ISO R773.
3. FLANGES ARE SMS/DIN/IDF.
4. W = WEIGHT IN KG.
5. FOR FULL CERTIFIED DRAWINGS REFER TO ROTOMAC, KANPUR (INDIA)

# ROTOMAC™

ROTOMAC INDUSTRIES PVT. LTD.

D-4A, PANKI INDUSTRIAL AREA, SITE-1,  
KANPUR - 208 022 (U.P.) INDIA

Tel: 2691704, 2691705; Fax: +91 (0512) 2691706

email: [rotomac@vsnl.net](mailto:rotomac@vsnl.net) ; [marketing@rotomacpump.com](mailto:marketing@rotomacpump.com)

Web: [www.rotomacpump.com](http://www.rotomacpump.com)

Note : Rights of technical changes reserved.

