

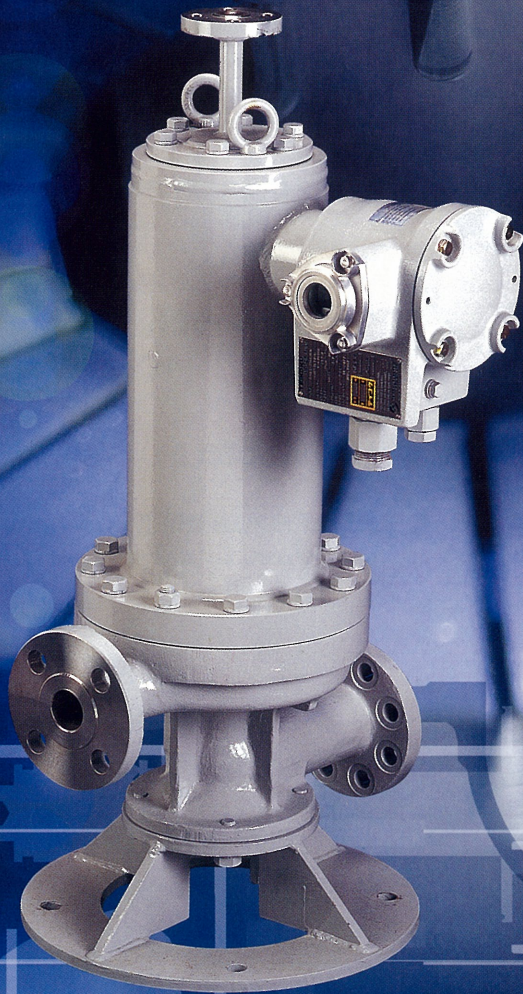

# CANNED MOTOR PUMPS

World's Largest Manufacturer of Canned Motor Pumps

ISO 9001 CERTIFIED



**TEIKOKU ELECTRIC MFG. CO., LTD.**

# A MODERN PUMP FOR A NEW MILLENNIUM

## Safety Meets Efficiency

The ever-increasing demand for environmental safety at a reasonable cost presents a unique challenge to the Process Industries: find and utilize equipment that, while operating leak-free, performs reliably and efficiently. Teikoku's Canned Motor Pump more than meets the challenge.

Besides double containment for total fluid control, the pump offers some remarkable performance advantages. Designed to enable long periods of time

between maintenance (with pre-planned downtime), it has only a few components that need to be monitored and serviced. It never requires costly alignment procedures or external lubrication. And, because it is sealless, the Teikoku Canned Motor Pump eliminates seal maintenance as well as the demands of complicated seal support systems.

The Teikoku Canned Motor Pump: true secondary containment, reliable operation, cost-efficiency...and continuing environmental concern.

---

## TEIKOKU CANNED MOTOR PUMPS

### NO LEAKAGE

Handles toxic, explosive, expensive, hazardous, carcinogenic and corrosive fluids without leaking.

### AIRTIGHT

Ideal for vacuum services or for fluids that react to contact with air.

### NO SHAFT SEAL

No mechanical seal. No gland packing.

### NO EXTERNAL LUBRICATION

Pumped fluid provides cooling and lubrication of motor and bearings. No lubrication levels to check or maintain.

### VACUUM to HIGH SYSTEM PRESSURE

Rated to handle conditions from full vacuum to 5,000 psi / 35 MPa.

### COMPACT DESIGN

Motor and pump are a single unit. No alignment is necessary. No grouting or elaborate foundation is needed.

### QUIET OPERATION

Low noise level since no fan is used to cool motor. All rotating parts are within a thick shell container.

### EXPLOSION PROOF

Certified by TIIS(Japan), PTB (Germany) and many other authorities

### API 610 NOZZLE LOADS

### FIELD REPAIRABLE

All wear parts are easily changed.

## ANSI SIZES & ISO2858 SIZES AVAILABLE

### ALL PUMPS PERFORMANCE TESTED

Every component of each pump is manufactured by Teikoku, adhering to strict statistical quality control tolerances, and each pump and motor are 100% performance-tested before shipment.

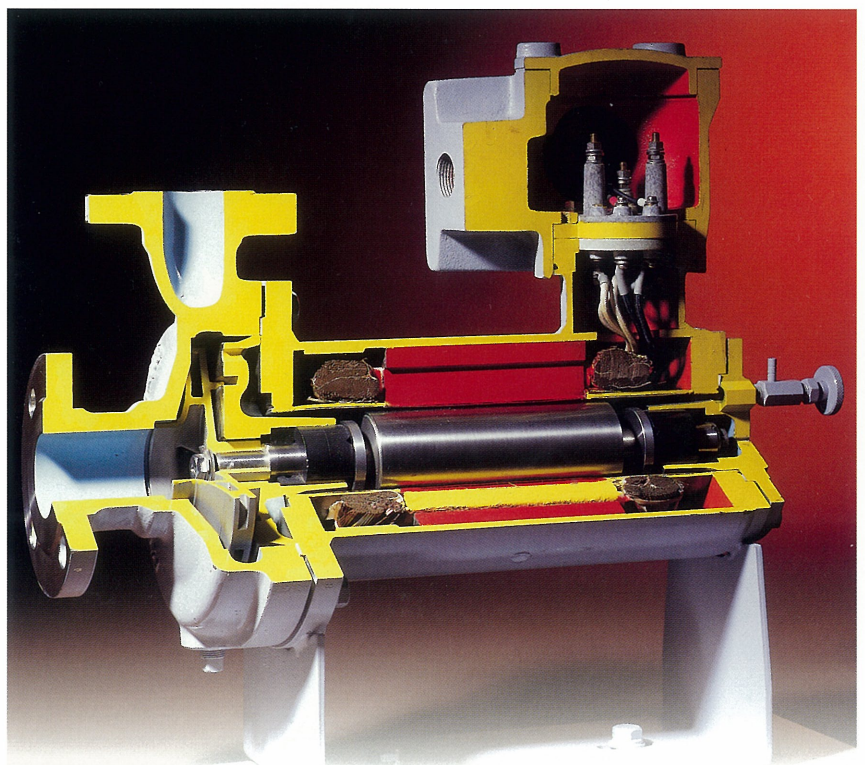

# COMPARE TEIKOKU TO: CENTRIFUGAL PUMPS WITH DOUBLE MECHANICAL SEALS

## MECHANICAL SEALS

Can cause total shutdown when they fail. No secondary containment.

## SEPARATE MOTOR AND PUMP

Must constantly be kept in proper alignment. Motor is exposed. A foundation is necessary to support the increased weight and reduce the danger of misalignment.

## TIME-CONSUMING MAINTENANCE

Motor and bearing lubrication levels must be continually monitored.

## ELEVATED NOISE LEVEL

Separate motor cooling fan is required. Rotating parts greatly add to the noise.

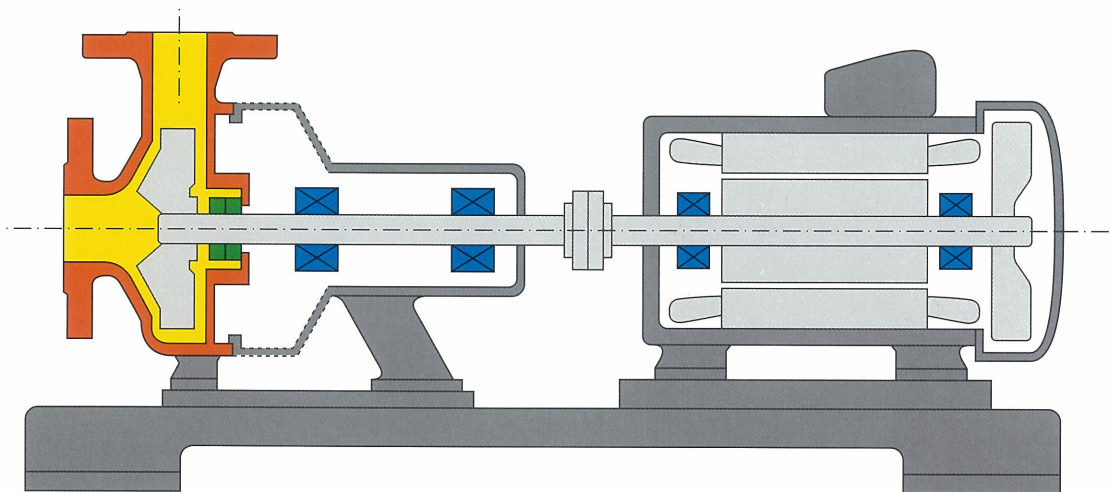

---

## MAGNET DRIVE PUMPS

### THIN CONTAINMENT SHELL

Subject to damage by magnets and subsequent leakage. No secondary containment.

### MANY BEARINGS

All must be checked frequently for proper lubrication. Bearings within impeller shaft cannot be easily monitored.

### DECOUPLING DUE TO PROCESS UPSET

Decoupling may lead to sudden catastrophic failure.

### SEPARATE MOTOR AND PUMP

Must constantly be kept in proper alignment. Motor is exposed. A foundation is necessary to support the increased weight and reduce the danger of misalignment.

### NOISY FAN

Needed to cool motor.

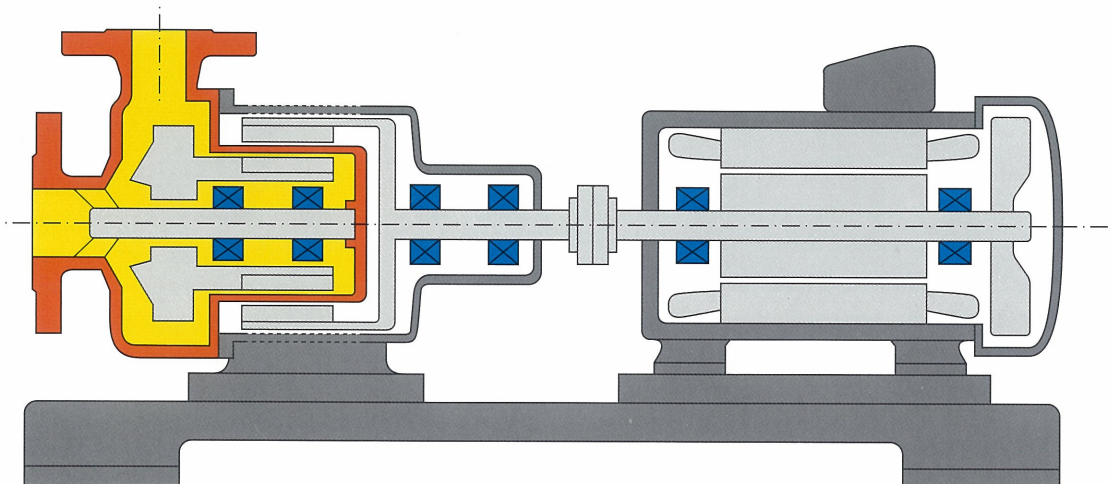

# TEIKOKU CANNED MOTOR PUMPS DESIGNED FOR ZERO LEAKAGE SERVICES IN THE CPI

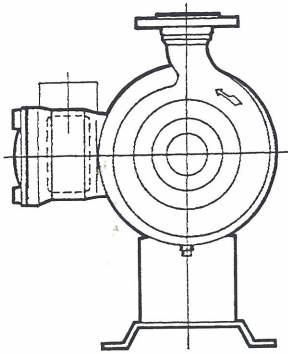

Centered Suction and Discharge for easier piping design and installation, with either ANSI or ISO raised face flanges or other standards as requested.

TEIKOKU, the world's largest supplier of canned motor pumps presents a state-of-the-art, sealless pump.

No newcomer to the field, TEIKOKU has provided customers with proven Canned Motor Pumps for 44 years. Over 400,000 units have been installed worldwide, covering every application.

TEIKOKU is unique in that we design and manufacture both pumps and motors, thus insuring our customers total quality control.

The TEIKOKU Canned Motor Pump replaces conventional sealed pumps providing safer, more efficient operation. This is especially advantageous when pumping hazardous or hard to handle materials.

## TEIKOKU THRUST BALANCE SYSTEM

Side Gap

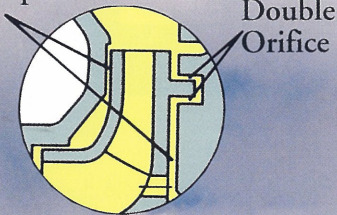

Noncontacting double orifice permits minimum leakage and improves volumetric efficiency. Enclosed impeller with optimum side gap keeps hydraulic losses at a minimum as well.

Vacuum dried, N<sub>2</sub> purged stator with Class C or F insulation

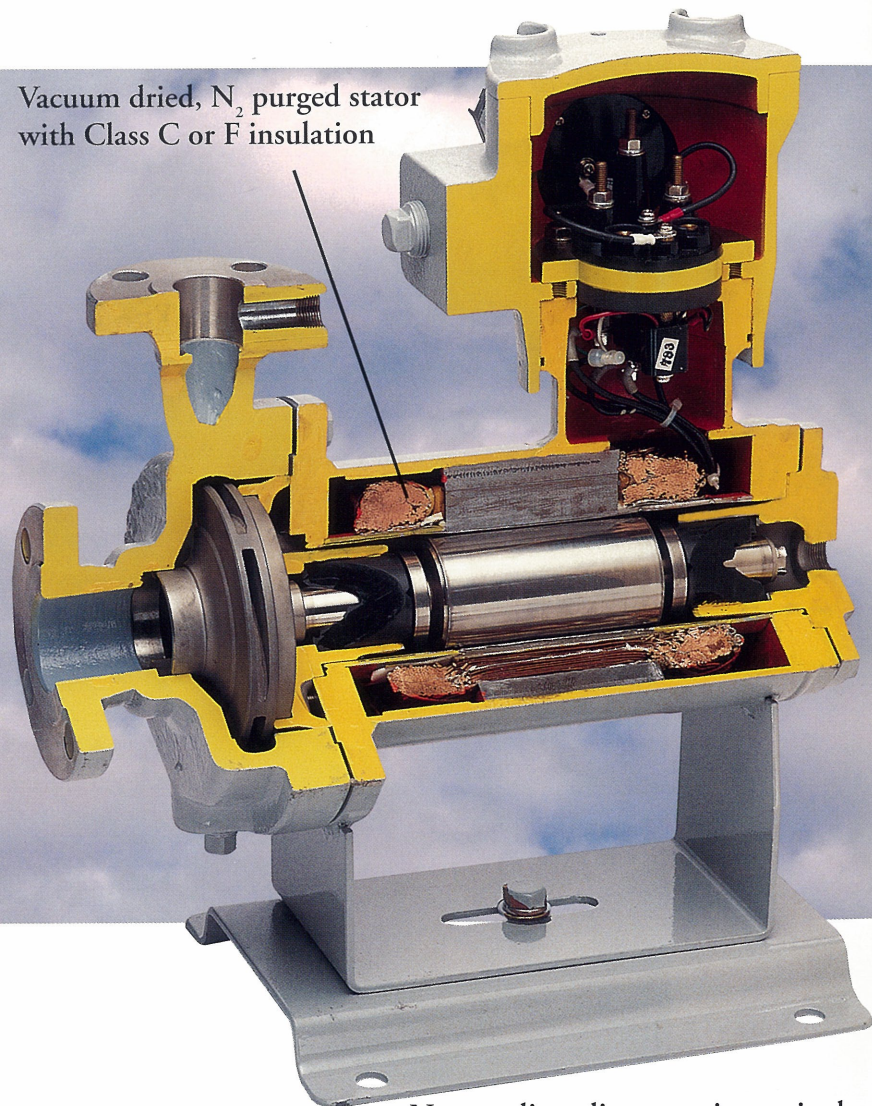

**No coupling alignment is required.  
No mechanical seal is required.**

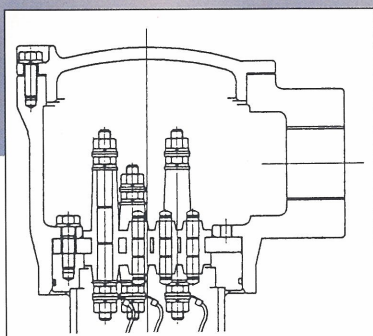

Improved terminal plates seal off higher pressure from inside, and a waterproof terminal box assures safe outdoor operation. All motor-pumps are provided with an explosion proof terminal box.

TEIKOKU provides expertise and assistance in selecting the pump best suited to our customer's specific needs. We have experience with horizontal standard pumps, vertical designs with either pump top or motor top, pumps and motors jacketed for either cooling or heating, self priming, submerged, slurry design, super-heat resistant pumps and more.

# TEIKOKU ROTARY GUARDIAN BEARING WEAR MONITOR

Each Teikoku Canned Motor Pump comes with the patented Teikoku Rotary Guardian (TRG) — an electrical meter that continuously monitors bearing wear. The TRG indicates any serious malfunction of the pump before a failure occurs; many users opt to have the TRG connected to an alarming device.

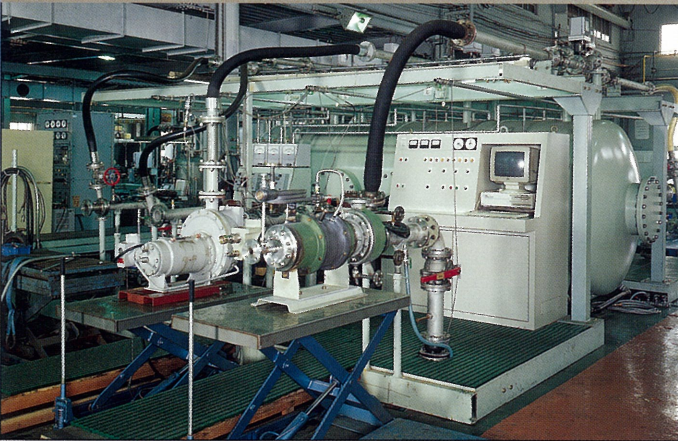
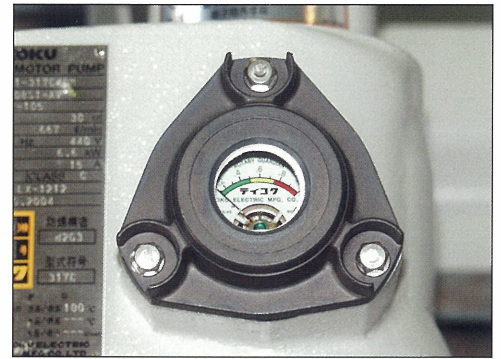
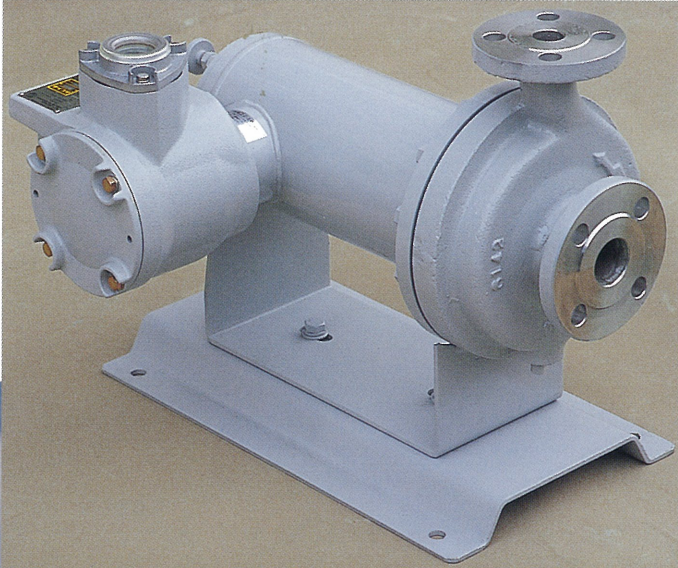

In Teikoku's factory testing lab, all pumps are 100% performance-tested before shipment.



## TEIKOKU ROTARY GUARDIAN (TRG)

Takes the "mystery" out of canned motor pump operation ... continuously monitors the critical running clearance between the stator and rotor.

The exclusive TRG system is the only electrical monitoring device available today that not only monitors the running clearance but indicates bearing condition. This allows the operator to plan for pump maintenance.

The exclusive TRG protection system makes TEIKOKU the most reliable canned motor pump in the industry today.

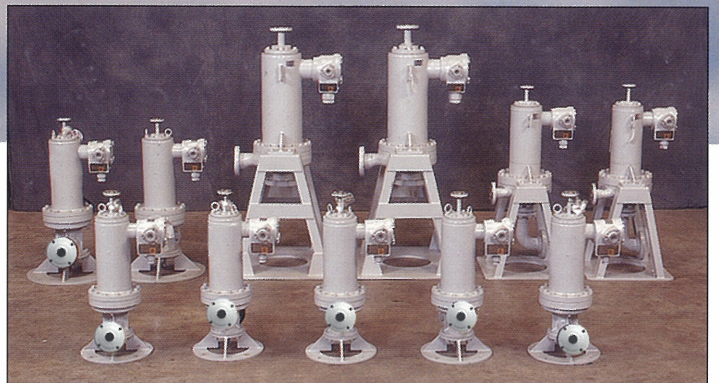

Teikoku's various product lines include zero-leakage canned motor pumps, mixers and accessories. All pumps are available in vertical configuration for longer pump life and minimal space usage in plants and other processing facilities.

# PUMP PERFORMANCE CURVE

3480/1740rpm

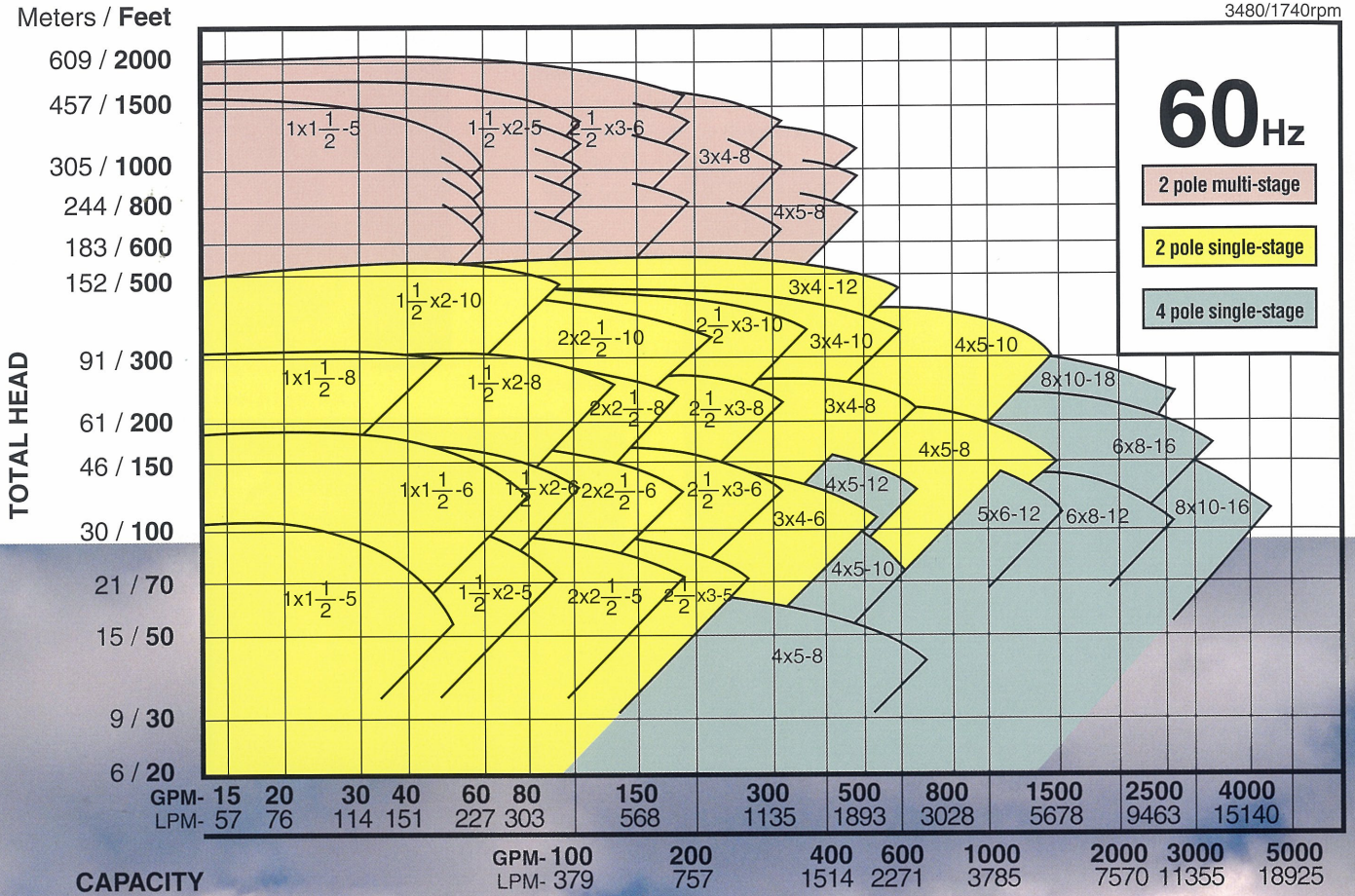

2900/1450rpm

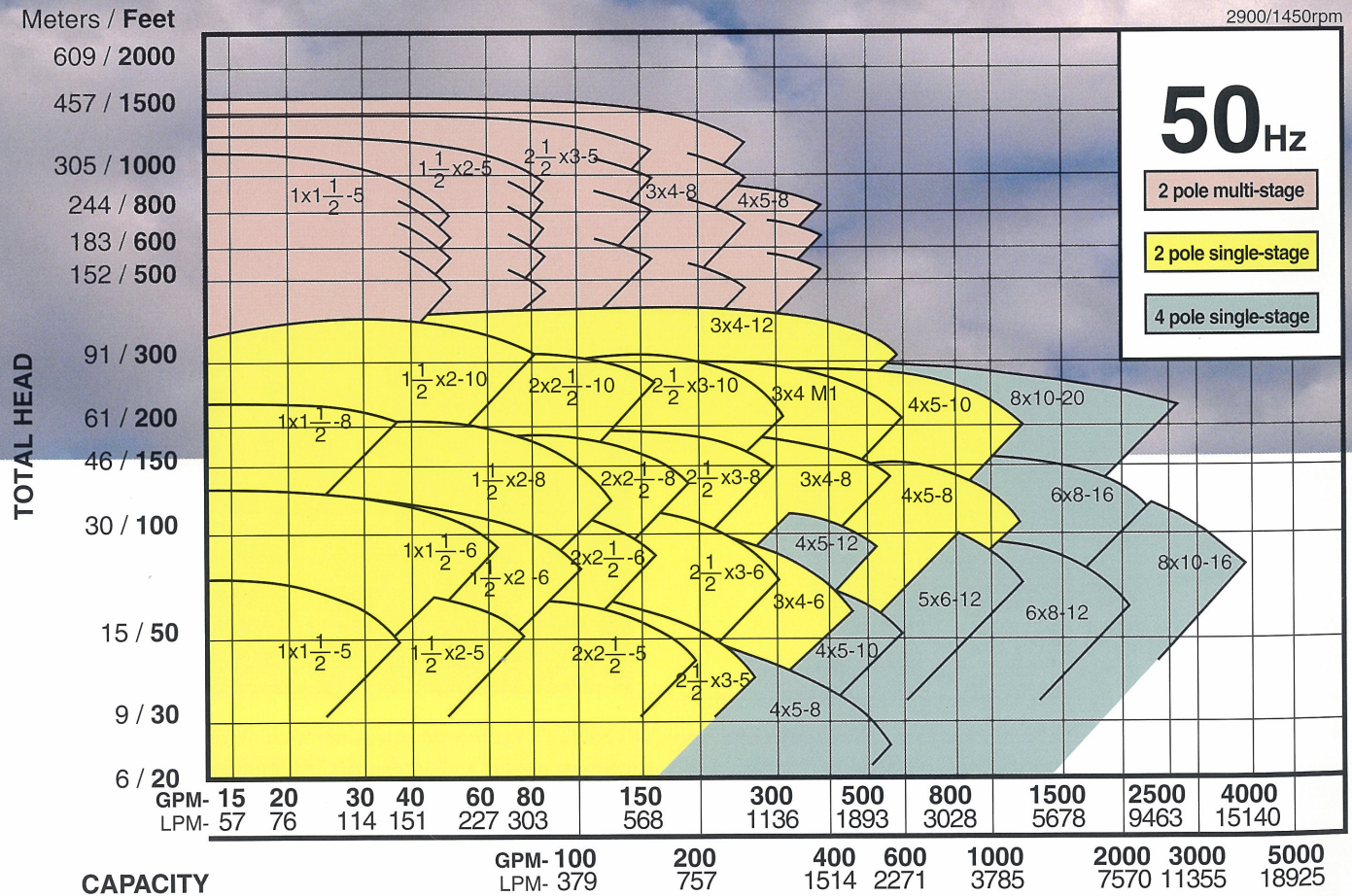

# TAILOR MADE TEIKOKU CANNED MOTOR PUMPS FOR DIVERSIFIED CUSTOMER NEEDS

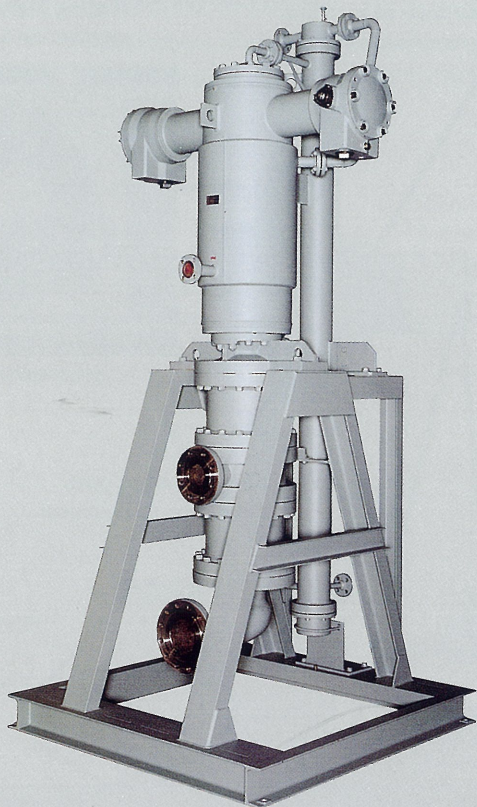
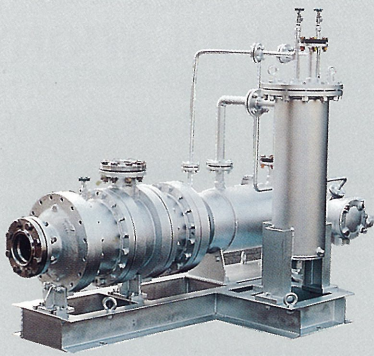

## Multistage Canned Motor Pumps

Vertical multistage pump with a 150 kw, 3,000 rpm canned motor pump for feeding 150 deg C feedstock at 100 m<sup>3</sup>/h and 30 bar differential pressure (bottom).

Horizontal multistage pump with a 120 kw, 3,600 rpm canned motor pump for circulation of hot oil (top).

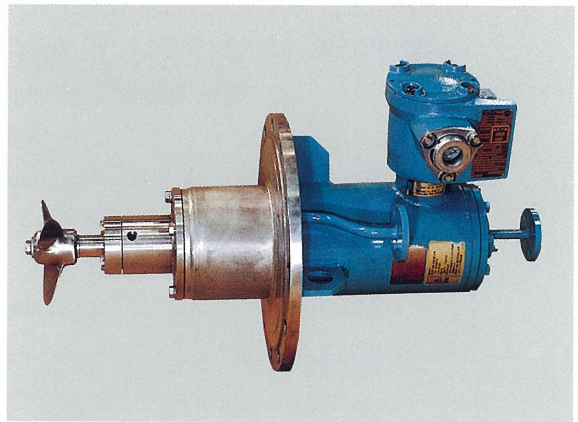

## Canned Motor Sealless Mixer

Teikoku Canned Motor Mixer is a breakthrough in mixing technology.

It eliminates the shaft seal, needs no external lubrication and guarantees leakage-free and maintenance free operation under full vacuum to high tank internal pressure.

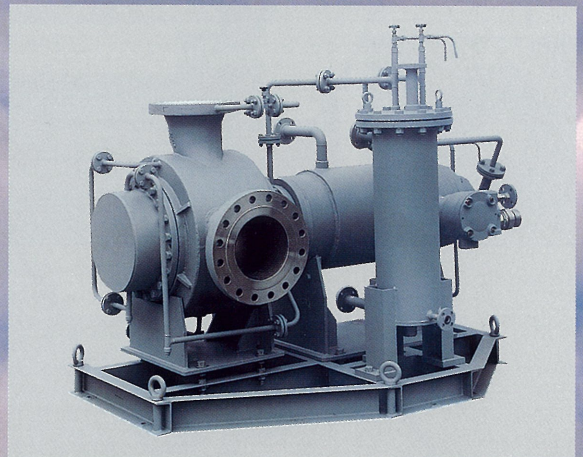

## Double Suction TCMP

350x350-400 Large flow, low head horizontal double suction TCMP for high temperature service. The pump casing is jacketed for heating and the motor housing is jacketed for cooling. The integrated vertical heat exchanger cools down the internal circulation/lubrication flow to insure motor cooling and bearing lubrication.

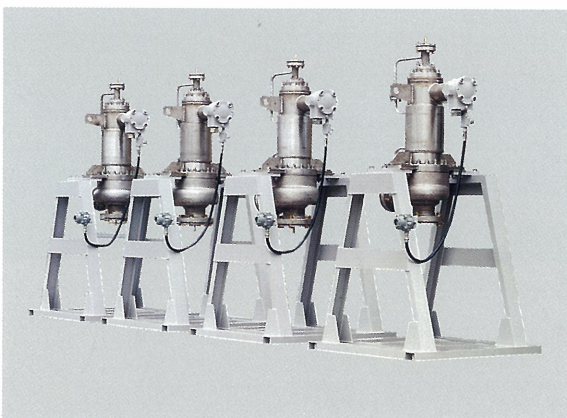

## Vertical Reverse Circulation TCMPs

Vertical reverse circulation pumps with motor on-top configuration for volatile liquid services at extremely low temperatures. The bearing wear monitor TRG is in an explosion proof box and mounted at a readable level on the pump base. The best solution to solve the seal problems when pumping thin and light liquids, including many hydrocarbons.

**HIGH TEMPERATURE** service pumps are available in two versions. Type F with ceramic insulated motor windings (no motor cooling is required) and Type B with cooling jacket on motor with class C insulation.

## TYPE F WITH X MOTOR (CERAMIC INSULATION) the simplest construction makes it more reliable

**Pump size** : 1.5 x 1 x 5 to 4 x 5 x 10  
**3,600 RPM motor** : 2 HP / 1.5 kw to 75 HP / 55 kw  
**1,800 RPM motor** : 5 HP / 3.7 kw to 25 HP / 18.5 kw  
 Maximum allowable liquid temperature, 750°F / 400°C. Standard pressure rating up to 430 psi/3 MPa.

ANSI RF flanges are standard. Other standards are also available.

Ceramic insulated motor windings withstand up to 752°F/400°C under continuous full load operation. No cooling required.

Extended motor leads to keep heat from reaching terminals and bearing monitors.

Bearing Monitor (TRG) is standard on all pumps.



Sealed terminal plate forms true containment.

Dynamically and hydraulically balanced single rotating element is FREE-FLOATING in the hot liquid. This allows no thermal stress or impact on either the shaft or the bearings. No degrading of alignment or coupling problems.

### TYPE BX (HIGH-TEMPERATURE-INSULATION TYPES)

In high temperature and frequent heat-cycle applications, a special tube recirculates the lubrication liquid WITHOUT NEED FOR EXTERNAL COOLING.

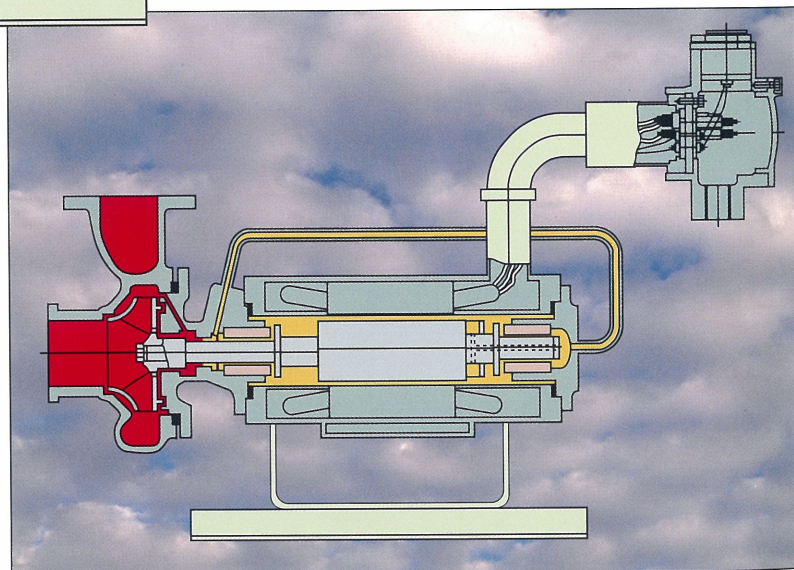



# TYPE B WITH BUILT-IN HEAT EXCHANGER AND MOTOR COOLING JACKET

- Toughest against temperature changes and all thermal upsets
- Wider selection than any other sealless pumps
- No mechanical seal, no ball bearings, no coupling -- No leakage
- Selections can be made from

**Pump size** : 1.5 x 1 x 5 to 8 x 10 x 15  
**3,600 RPM motor** : 1.5 HP / 1.1 kw to 267 HP / 200 kw  
**1,800 RPM motor** : 3 HP / 2.2 kw to 213 HP / 160 kw  
 Maximum allowable liquid temperature, 850°F / 455°C regardless of the motor size. Pressure rating up to 5,000 psi/35 MPa.

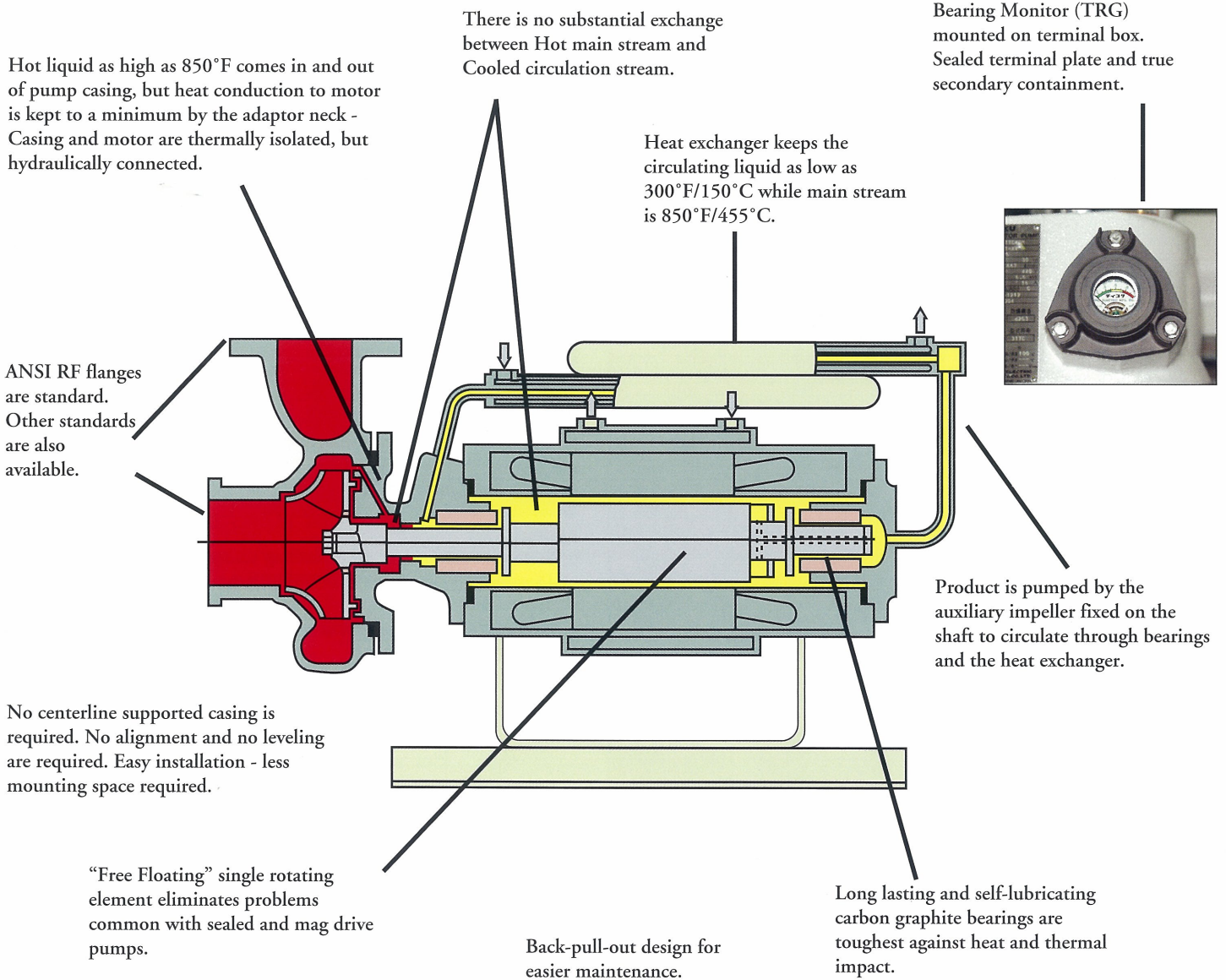

# MOTOR RATINGS

## STANDARD TEIKOKU CANNED MOTORS

### 2 Pole Motors

Motor Frame #	Rate Output (kw/hp)	Nominal Voltage (V)	60 Hz		50 Hz	
			Rated Amp. (A)	Start Amp. (A)	Rated Amp. (A)	Start Amp. (A)
119	0.75/1	400	2.2	10	2.4	11
		440	2.2	10.5	—	—
	1.1/1.5	400	3.0	10	3	11
		440	2.7	10.5	—	—
215	1.3/1.7	440	3	10.5	—	—
		400	3.3	14.5	3.3	17
	1.1/1.5	440	3.0	16	—	—
		400	3.8	14.5	3.8	17
216	1.5/2	440	3.6	16	—	—
		400	3.8	22	—	—
	2.2/2.9	440	5.1	24	—	—
		400	5.5	24	—	—
217	2.5/3.3	440	7.5	25	7.5	28
		400	6.7	27	—	—
	3/4	440	7.5	27	—	—
		400	9	51	10	58
316	3.7/4.9	440	9	55	—	—
		400	13	51	13	58
	5.5/7.3	440	11.5	55	—	—
		400	13	55	—	—
317	6.6/8.8	440	16	53	16	61
		400	15	58	—	—
	7.4/9.9	440	16	58	—	—
		400	16	92	17	106
416	7.5/10	440	16	101	—	—
		400	23	92	23	106
	11/14.7	440	21	101	—	—
		440	23	101	—	—
417	12/16	440	33	119	33	136
		400	30	130	—	—
	15/20	440	33	130	—	—
		400	31	137	33	158
516	17/23	440	31	150	—	—
		400	39	137	39	158
	20/27	440	36	150	—	—
		400	39	150	—	—
518	22/29	440	48	182	48	210
		400	44	200	—	—
	26/35	440	55	182	55	210
		400	51	200	—	—
616	29/39	440	55	200	—	—
		400	57	229	61	264
	30/40	440	57	251	—	—
		400	74	229	74	264
617	37/49	440	69	251	—	—
		400	74	251	—	—
	40/53	440	90	286	90	331
		400	84	314	—	—
716	50/67	440	90	314	—	—
		400	102	588	110	690
	55/73	440	102	646	—	—
		400	126	588	126	690
717	65/87	440	118	646	—	—
		400	145	588	145	690
	75/100	440	134	646	—	—
		400	145	646	—	—
815	85/113	440	175	774	175	918
		400	162	850	—	—
	90/120	440	185	850	—	—
		400	210	774	210	918
817	110/147	440	194	850	—	—
		400	210	850	—	—
	120/160	440	262	763	262	884
		400	242	840	—	—
817	132/176	440	262	840	—	—
		400	370	1270	388	1500
	180/240	440	370	1400	—	—
		400	410	1270	430	1500
200/267	440	410	1400	—	—	

### 4 Pole Motors

Motor Frame #	Rate Output (kw/hp)	Nominal Voltage (V)	60 Hz		50 Hz	
			Rated Amp. (A)	Start Amp. (A)	Rated Amp. (A)	Start Amp. (A)
326	1.5/2	400	8	38	8	43
		440	7	41	—	—
	2.2/2.9	400	8.5	38	8.5	43
		440	8	41	—	—
	3.7/4.9	400	10.5	38	10.5	43
		440	10	41	—	—
	4.2/5.6	400	—	—	—	—
		440	10.5	41	—	—
426	5/6.7	440	12	41	—	—
		400	16	69	16	78
	5.5/7.3	440	15	75	—	—
		400	19	69	19	78
	7.5/10	440	18	75	—	—
		400	19	75	—	—
	8.5/11.3	440	19	75	—	—
		400	28	113	28	130
526	11/14.7	440	26	124	—	—
		400	35	113	35	130
	15/20	440	32	124	—	—
		440	35	124	—	—
626	17/23	400	43	173	43	200
		440	40	190	—	—
	18.5/25	400	49	173	49	200
		440	45	190	—	—
726	22/29	440	49	190	—	—
		400	71	271	71	312
	30/40	440	65	297	—	—
		400	83	271	83	312
728	37/49	440	77	297	—	—
		400	83	297	—	—
	40/53	400	105	450	105	515
		440	95	490	—	—
825	45/60	400	124	450	124	515
		440	115	490	—	—
	55/73	440	124	490	—	—
		400	140	500	140	500
829	62/83	440	165	500	165	500
		400	130	500	—	—
	65/87	400	165	500	—	—
		440	150	500	—	—
829	75/100	440	165	500	—	—
		400	250	1054	270	1250
	85/113	440	250	1160	—	—
		400	310	1054	310	1250
829	110/147	440	285	1160	—	—
		400	310	1160	335	1110
	132/176	440	310	1160	—	—
		440	335	1030	—	—

#### Notes:

1. For actual voltage and corresponding amperage, refer to the Technical Data Sheet issued for each individual order.
2. Motors are available with insulation class R and with or without cooling/heating jacket.

## Product Range/Limitations on Application

	Standard		Upon Request	
CAPACITY (max)	4,227 GPM	16 m <sup>3</sup> /min	10,500 GPM	40 m <sup>3</sup> /min
TDH (max)	2,000 ft.	609 m	2,500 ft.	750 m
TEMPERATURE*	-112 to 716°F	-80 to 380°C	-328 to 842°F	-200 to 450°C
VISCOSITY (max)	100 cst	100 cst	350 cst	350cst
DESIGN PRESSURE (max)	430 psi	3 MPa	7,900 psi	55 MPa
MOTOR HORSEPOWER (max)	267 HP	200 KW	667 HP	500 KW
MAJOR MATERIALS <sup>a</sup> OF WETTED PARTS	304SS, 316SS		304LSS, Hastelloy, Titanium, alloy 20	

\*temperature of pumped liquid

## Quality Assurance

All motors and pumps are designed and manufactured by TEIKOKU under its full quality control program. Every motor-pump is inspected and tested before shipment. The QC program consists of the following tests and inspections.

- Applied to all pumps, data furnished to customer if required.**
- Applied to all pumps, no data available to customer.**
- Applied to all pumps, data submitted to customer.**
- Test done only upon customer request, data submitted to customer.**

### I. MOTOR

1-1	Measurement of resistance between terminals (main power coils).....	<input checked="" type="radio"/>
1-2	No load test.....	<input checked="" type="radio"/>
1-3	Locked rotor test.....	<input checked="" type="radio"/>
1-4	Surge test.....	<input type="radio"/>
1-5	Insulation test.....	<input type="radio"/>
1-6	Dielectric strength test.....	<input type="radio"/>
1-7	Temperature rise test.....	<input type="radio"/>
1-8	Measurement of resistance between terminals (TRG coils).....	<input type="radio"/>

### II. PUMP PERFORMANCE

2-1	Capacity vs head, current, input.....	<input type="radio"/>
2-2	NPSH test.....	<input type="radio"/>
2-3	Capacity vs TRG output measurement.....	<input type="radio"/>
2-4	Thrust force and circulation flow measurement.....	<input type="radio"/>
2-5	TRG output check for reverse rotation.....	<input type="radio"/>

### III. OTHERS

3-1	Vibration test.....	<input type="radio"/>
3-2	Noise test.....	<input type="radio"/>
3-3	Dimensional check.....	<input type="radio"/>
3-4	Hydrostatic test.....	<input type="radio"/>
3-5	Pneumatic test.....	<input type="radio"/>
3-6	Vacuum test.....	<input type="radio"/>
3-7	Halogen leak test.....	<input type="radio"/>
3-8	Mechanical seal leak test (slurry design).....	<input type="radio"/>
3-9	Priming test (for type G only).....	<input checked="" type="radio"/>
3-10	Mill certificate on metallic materials.....	<input type="radio"/>
3-11	ND tests on metals and weldings.....	<input type="radio"/>

# BASIC VERSIONS

## F-V TYPE (BASIC TYPE WITH HOLLOW SHAFT)

Fundamental design of TEIKOKU Motor Pump. Most commonly used for a wide variety of applications.

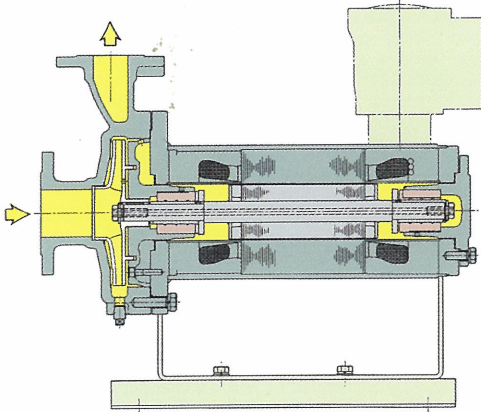

## FA-V TYPE (BASIC TYPE WITH HOLLOW SHAFT)

Fundamental design of TEIKOKU Motor Pump, but with adapter to increase motor and pump combinations.

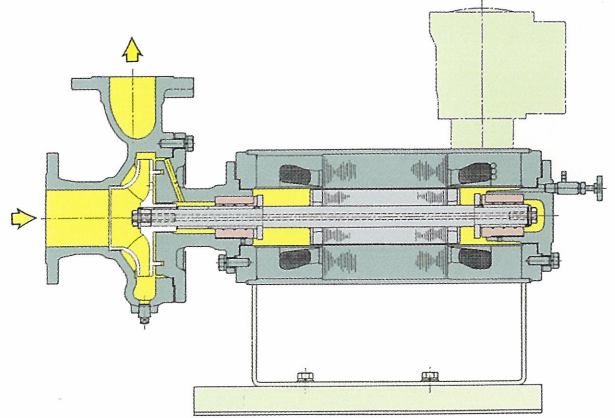

## RW/RV AND/OR FW/FV (VERTICAL IN-LINE)

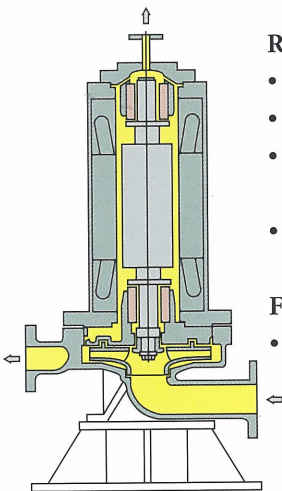

### RW or RV (Reverse Circulation)

- Improves Venting
- Improves Bearing Load
- Recommended for Low Viscosity and Steep Vapor Pressure Liquids
- Minimum Space Required

### FW or FW (Hollow Shaft)

- Minimum Space Required

## R TYPE (REVERSE CIRCULATION TYPE)

Suitable for handling volatile fluids, such as Ammonia, Freon, and other liquified gases, and for very low NPSH applications.

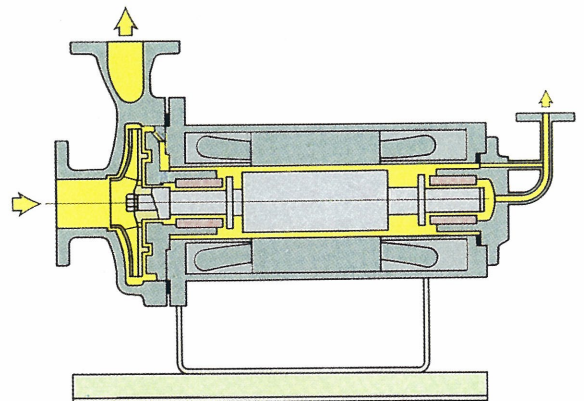

## K-S TYPE (FULL-STEAM-JACKET TYPE)

Suitable for handling fluids with high melting points.

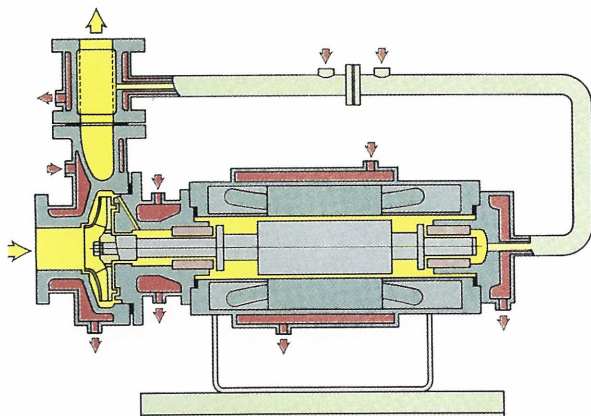

## K TYPE (FULL-STEAM JACKET TYPE)

Similar to K-S type, but for fluids with lower melting point.

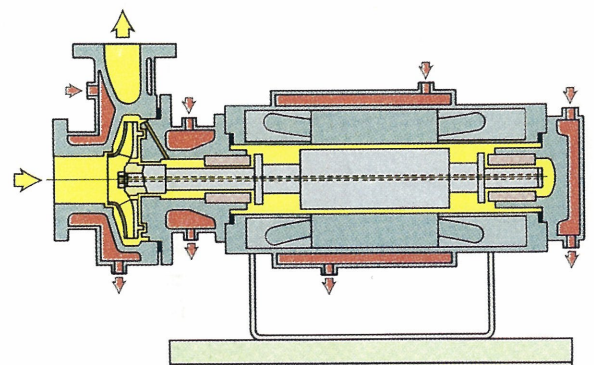

### **B TYPE (HIGH-TEMPERATURE-INSULATION TYPES)**

Suitable for handling high temperature fluids, such as heat transfer oil.

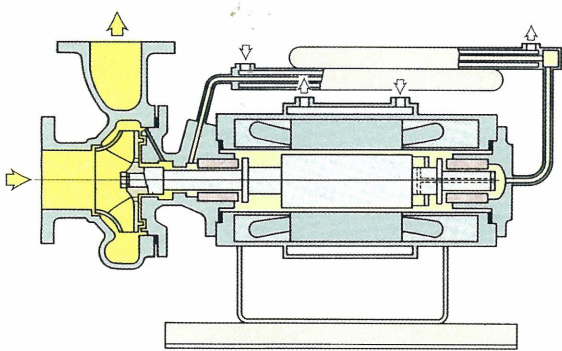

### **X TYPE (HIGH-TEMPERATURE-INSULATION TYPES)**

Suitable for handling high temperature fluids, such as heat transfer oil.

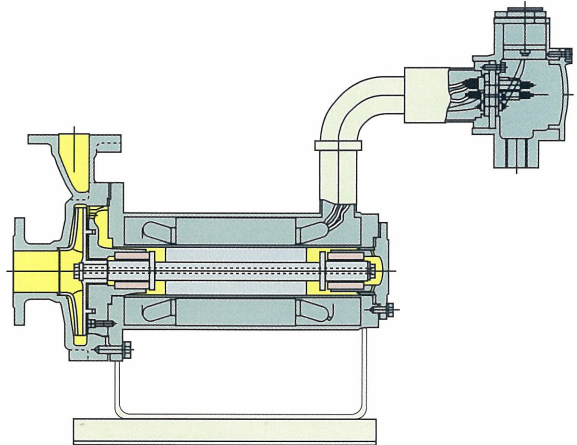

### **G TYPE (SELF-PRIMING TYPE)**

Used for pumping fluids from underground tank or rail/tank truck unloading.

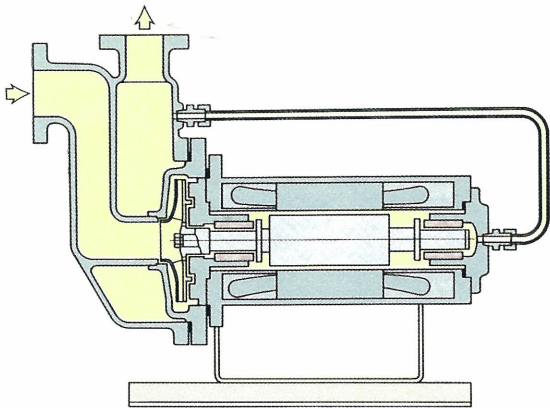

### **XG TYPE (GAS-SEALED SLURRY TYPE)**

Handles fluid with considerable slurry. Besides XG-type, SG-type with external flushing is also available.

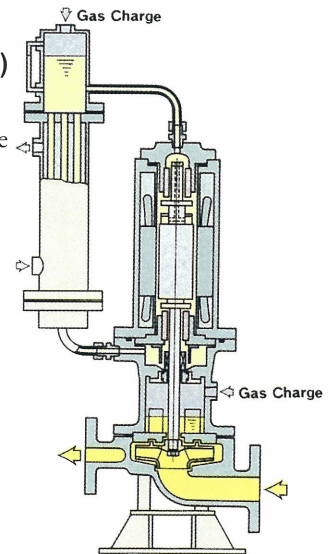

### **F-M TYPE (MULTI-STAGE TYPE)**

Higher head, higher efficiency pump. Besides F-M type, R-M (Reverse Circulation) type and B-M (High Temp-Insulation) type are also available.

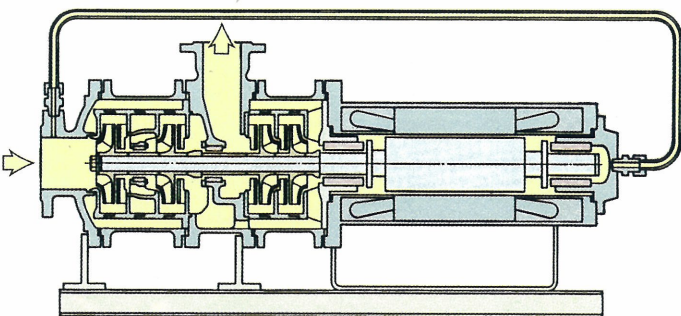

### **D TYPE (SLURRY SEAL TYPE)**

Suitable for handling fluids containing small amounts of fine solids.

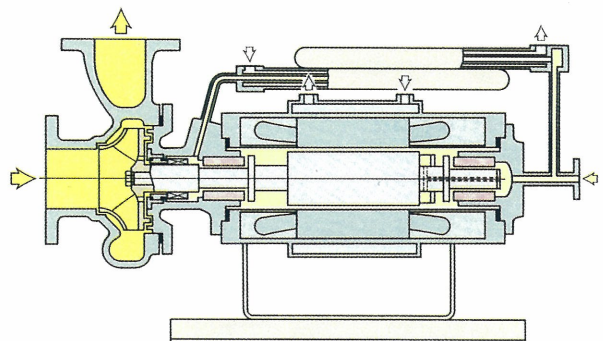

# FLUIDS PUMPED BY TEIKOKU

Acetaldehyde	Cyclohexylamine	Kerosene	1,2-Propanediol
Acetic acid	Developer	Ketene	1,3-Propanediol
Acetic anhydride	Dibutyl phthalate	Lactic acid (d or l)	2-Propanol
Acetone	Dichloroacetic acid	dl-Lactic acid	Propionaldehyde
Acetone cyanhydrin	m-Dichlorobenzene	Lactonitrile	Propionic acid
Acetonitrile	o-Dichlorobenzene	Lanthanum hydroxide	Propylene
Acrolein	p-Dichlorobenzene	Latex	Propylene oxide
Acrylic acid	1,1-Dichloroethylene	Lauric acid	Pyridine
Acrylonitrile	cis-1,2-Dichloroethylene	Lead (II) nitrate	Racemic acid
A-Heavy oil	trans-1,2-Dichloroethylene	Ligroin	Sea water
Aldol	1,1-Dichloropropane	Liquified petroleum gas	Silicone oil
Allyl alcohol	1,2-Dichloropropane	Liquid ammonia	Silicone tetrachloride
Allyl chloride	1,3-Dichloropropane	Liquid paraffin	Sodium acetate
Aluminium hydroxide	2,2-Dichloropropane	Lithium chloride	Sodium carbonate
Aluminium potassium	2,3-Dichloropropane	Lithium bromide	Sodium chlorate
Aluminium potassium sulfate	1,1-Dichloropropylene	Maleic acid	Sodium chloride
Aluminium sulfate	1,2-Dichloropropylene	Maleic anhydride	Sodium cyanide
2-Aminoethanol	2,3-Dichloropropylene	1-Malic acid	Sodium dithionate
Ammonium carbonate	3,3-Dichloropropylene	Manganese (II) chloride	Sodium formate
Ammonium chloride	cls-1,3-Dichloropropylene	Mercury	Sodium hydrogensulfate
Ammonium hydrogensulfide	trans-1,3-Dichloropropylene	Methacrylic acid	Sodium hydrogensulfite
Ammonium sulfate	Diethanolamine	Methanol	Sodium hydroxide
Ammonium tetrachlorozincate	Diethylamine	Methyl acetate	Sodium hypochlorite
Ammonium thiocyanate	Diethylene glycol	Methyl acetoacetate	Sodium metaphosphate
Aniline	Diethylene glycol monoethyl ether	Methyl acrylate	Sodium molybdate
Anisole	Di-2-ethylhexyl phthalate	Methylamine	Sodium nitrite
Anthracene oil	Diketene	Methyl bromide	Sodium peroxide
Aqueous ammonia	Dimethylamine	Methyl chloride	Sodium silicate
Barium sulfide	2-Dimethylaminoethanol	Methylchloroform	Sodium sulfate
Barium tetrasulfide	N,N-Dimethylformamide	Methyl chloroformate	Sodium sulfide
Barium trisulfide	2,3-Dimethylphenol	Methylchlorophenoxyacetic acid	Sodium sulfite
Benzaldehyde	2,4-Dimethylphenol	Methylene chloride	Sodium thiosulfate
Benzene	2,5-Dimethylphenol	Methyl ether	Solvent naphtha
Benzen chloride	2,6-Dimethylphenol	Methylisobutyl ketone	Soy
Benzine	3,4-Dimethylphenol	Methyl methacrylate	Stearic acid
Benzyl alcohol	3,5-Dimethylphenol	2-Methylpyridine	Styrene
Benzyl chloride	2,3-Dimethylpyridine	3-Methylpyridine	Sulfur
Boron oxide	Dimethyl sulfate	4-Methylpyridine	Sulphur dichloride
1,2-Butadiene	Dimethyl sulfite	Methyl sulfide	Sulphur dioxide
1,3-Butadiene	1,3-Dioxane	Morpholine	Sulphur trioxide
Butane	1,4-Dioxane	Naptha	Sulfuric acid
1-Butanol	Dipropylene glycol	Naphthalene	Tallow
di-2-Butanol	Epichlorohydrin	Nickel (II) chloride	Tetrahydrofuran
Butyl acetate	Ethanol	Nickel (II) nitrate	2,3,4,5-Tetrahydrophthalic acid
Butyl acrylate	Ethyl acetate	Nitric acid	3,4,5,6-Tetrahydrophthalic acid
tert-Butyl alcohol	Ethyl acrylate	Nitrobenzene	Thinner
Butylaldehyde	Ethylbenzene	Nitrogen dioxide	Thiourea
Butylamine	Ethyl chloroformate	m-Nitrotoluene	Tin (II) chloride
dl-sec-Butylamine	Ethylene chloride	o-Nitrotoluene	Titanium (IV) chloride
tert-Butylamine	Ethylenediamine	p-Nitrotoluene	Toluene
Cadmium nitrate	Ethylene glycol	w-Nitrotoluene	m-Toluidine
Calcium chlorate	Ethylene oxide	2-Nitro-m-xylene	o-Toluidine
Calcium chloride	Ethyl ether	4-Nitro-m-xylene	p-Toluidine
Calcium hydroxide	Ethyl chloride	5-Nitro-m-xylene	1,2,3-Trichlorobenzene
Calcium hypochlorate	Ethyl=d=lactate	3-Nitro-o-xylene	1,2,4-Trichlorobenzene
Calcium sulfite	Ethyl methyl ketone	4-Nitro-o-xylene	1,3,5-Trichlorobenzene
Caprolactam	5-Ethyl-2-methylpyridine	2-Nitro-o-xylene	1,1,2-Trichloroethane
Carbon bisulfide	Fatty acid	1-Octanol	Trichloroethylene
Carbon dioxide	Freon R-11	Octyl chloride	Tri-m-cresyl phosphate
Carbon tetrachloride	Freon R-12	Oleic acid	Tri-o-cresyl phosphate
Chloral	Formaldehyde	Orthoboric acid	Tri-p-cresyl phosphate
L-Chlorine	Formimide	Oxalic acid	Triethylamine
Chlorine dioxide	Formic acid	Paraffin	Trethylene glycol
Chloroacetic acid	Fuming sulfuric acid	Paraldehyde	Trimethylamine
Chloracetone	Furfural	Pentachloroethane	Urea
m-Chloroaniline	Furfuryl alcohol	Phenol	Vinegar
o-Chloroaniline	Gasoline	m-Phenosulfonic acid	Vinyl acetate
p-Chloroaniline	D-Glucose	o-Phenosulfonic acid	Vinyl chloride
Chlorobenzene	Glycerin	p-Phenosulfonic acid	Vinylidene chloride
Choroform	Glycine	Phosgene	Water
Chromium (VI) oxide	Heavy Water	Phosphorus trichloride	m-Xylene
Chlorosulfuric acid	Hydrazine	Phosphoryl chloride	o-Xylene
Citric acid	Hydrogen chloride	Phthalic acid	p-Xylene
Coconut oil	Hydrogen cyanide	Phthalic anhydride	p-Xylidine
Copper (II) hydroxide	Hydrogen fluoride	Potassium carbonate	sym, m-Xylidine
Copper (II) sulfate	Hydrogen peroxide	Potassium chlorate	unsym, m-Xylidine
m-Cresol	Hydrogen sulfide	Potassium cyanide	unsym, o-Xylidine
o-Cresol	Hydrofluoric acid	Potassium hydroxide	vic, m-Xylidine
p-Cresol	Iron (II) oxide	Potassium permanganate	vic, 0-Xylidine
Croasote oil	Iron (II) sulfate	Potassium phosphate	Zinc oxide
Crotonaldehyde	Isobutyl alcohol	Potassium sulfate	
Cyanoacetic acid	Isobutyl aldehyde	Propane	
Cyclohexane			
Cyclohexane			
Cyclohexanone			

# SAFETY OPTIONS

## TRG AMPLIFIER FOR ALARM & PROTECTOIN FROM DRY RUN

To achieve the optimum protection for TEIKOKU canned motor pumps against contingent failures, protection devices can be provided in addition to the visual type TRG meter.

The TRG output voltage can be connected to either an optical or acoustic alarm circuit, and/or to the main power with pump shut down capability.

The TRG amplifier contains an adjustable dial that provides a more flexible protection program.

Installed on the control panel as part of the electrical wiring, the Low Flow Alarm automatically cuts off the main power to the TEIKOKU canned motor when the pump runs dry. It also protects canned motor pumps from excessive cavitation. Typical uses include:

1. Unloading tank trucks.
2. Pumping from storage tanks.
3. Batch operations.
4. Any other application where pump can possibly run dry.

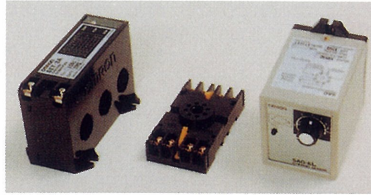

Protection from Dry Run

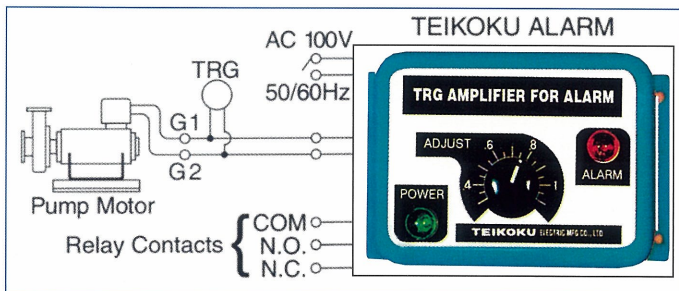

TRG Amplifer for Alarm

## NEW COMPACT DIGITAL PUMP LOAD CONTROL

### Detect Loss of Load

- Dry running
- No prime
- Cavitation

### Detect Overload

- Jammed impeller
- Bad bearings

### 2 Adjustable Set Points

**LOW TRIP** - When load is below the Low Trip, the built-in relay will trip

- Dry running
- Loss of prime
- Plugged or closed inlet

**HIGH TRIP** - When the load is above the High Trip, the built-in relay will trip

- Jammed impeller
- Bearing failure

### Filter Out Nuisance Trips

- Adjustable Digital On-Delay Timers: Trip won't activate until the selected delay time is exceeded.
- Adjustable Digital Start-up Timer: no false trips while motor is starting



## THERMOWELL

Certain applications demand extra attention to thermal conditions. Teikoku can provide thermowells on their pumps to detect extreme temperature operations. The heavy-duty thermowells are designed to accommodate a wide variety of temperature indicating devices.

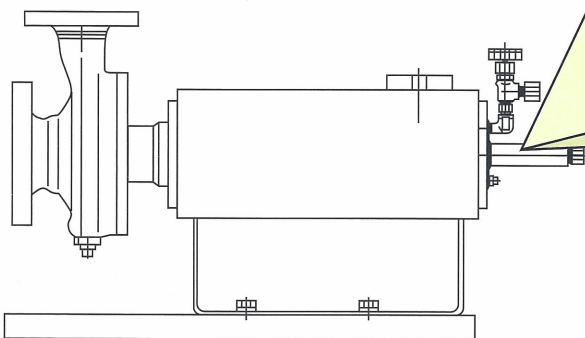

CONTACT TEIKOKU FOR OTHER AVAILABLE OPTIONS.



# TEIKOKU Group Global Network

## TEIKOKU Electric Mfg.Co., Ltd. (Japan)

### Plant & Business Headquarters

Postcode 679-4395

60 Hirano, Shingu-Cho, Tatsuno-Shi, Hyogo-Ken, Japan

Phone : +81-791-75-0411

Fax : +81-791-75-4190

### International Business Headquarters

Postcode 110-0015

6F Shitaya Bldg.

2-5, 5-chome, Higashi-Ueno, Taito-Ku, Tokyo, Japan

Phone : +81-3-3841-9311

Fax : +81-3-3841-7334

E-mail : [ibd-tokyo@teikokudenki.co.jp](mailto:ibd-tokyo@teikokudenki.co.jp)

## TEIKOKU USA INC. & CHEMPUMP Div. (North & South America)

### TEIKOKU USA INC.

7010 Empire Central Dr. Houston, TX 77040-3214

Phone +1-713-983-9901

Fax +1-713-983-9919

E-mail [info@teikoku-usa.com](mailto:info@teikoku-usa.com)

Web [www.teikoku-usa.com](http://www.teikoku-usa.com)

### CHEMPUMP Div.

959 Mearns Road, Warminster, PA 18974

Phone +1-215-343-6000

Fax +1-267-486-1037

E-mail [chempump@chempump.com](mailto:chempump@chempump.com)

Web [www.teikoku-usa.com](http://www.teikoku-usa.com)

### TEIKOKU Electric GmbH (Europe)

Nuernberger Strasse 24, D-40599 Duesseldorf

Germany

Phone +49-211-700-6778

Fax +49-211-749-0011

E-mail [info@teikoku-electric.de](mailto:info@teikoku-electric.de)

Web [www.teikokupump.de](http://www.teikokupump.de)

### DALIAN TEIKOKU CANNED MOTOR PUMP CO., LTD. (China)

中国大连三涧堡工业科技园区

Sanjianpu Science & Technology Industry

Area, Dalian, China

Phone +86-411-8626-9657

Fax +86-411-8626-9292

Web [www.teikoku-china.com](http://www.teikoku-china.com)

### TEIKOKU SOUTH ASIA PTE LTD.

No.15, Joo Koon Crescent, Singapore 629015

Phone +65-6861-4121

Fax +65-6861-4521

E-mail [info@teikoku-sa.com.sg](mailto:info@teikoku-sa.com.sg)

Web ( see US website )

### TEIKOKU KOREA CO., LTD.

3F Hannam Tower Annex Bldg. II, #730

Hannam-dong, Yongsan-gu, Seoul, Korea

Phone +82-2-790-7012

Fax +82-2-790-7014

E-mail [webmaster@teikokukorea.co.kr](mailto:webmaster@teikokukorea.co.kr)

Web [www.teikokukorea.co.kr](http://www.teikokukorea.co.kr)

### TAIWAN TEIKOKU PUMP CO., LTD.

9F-1, No.5, Jinzhou st., Zhongshan District,

Taipei City 104, Taiwan, R.O.C.

Phone +886-2-2567-9800

Fax +886-2-2568-2670

E-mail [tppco@ms32.hinet.net](mailto:tppco@ms32.hinet.net)

Web ( see US website )

ISO 9001  
ISO 14001  
BUREAU VERITAS  
Certification



ATEX